

Decarbonisation of Winter Tourism by Hydrogen Powered Fuel Cell Snowmobiles

A3PS Vienna, Nov 19th, 2020

A3PS Conference Eco-Mobility 2020
Nigel Foxhall



Confidential & Property of the HySnow Consortium

High Level Goals of HySnow



Sustainable vehicles & infrastructure

- **Research on key issues** regarding freeze start and degradation of FC
- **Development of hydrogen-powered fuel cell snowmobile**
- **Development of sustainable on-site hydrogen refueling station**
- **Demonstration of two vehicles over two winter seasons**
- **Basis for subsequent series development and paradigm change of propulsion technology**

Hydrogen Ecosystem for Winter Tourism

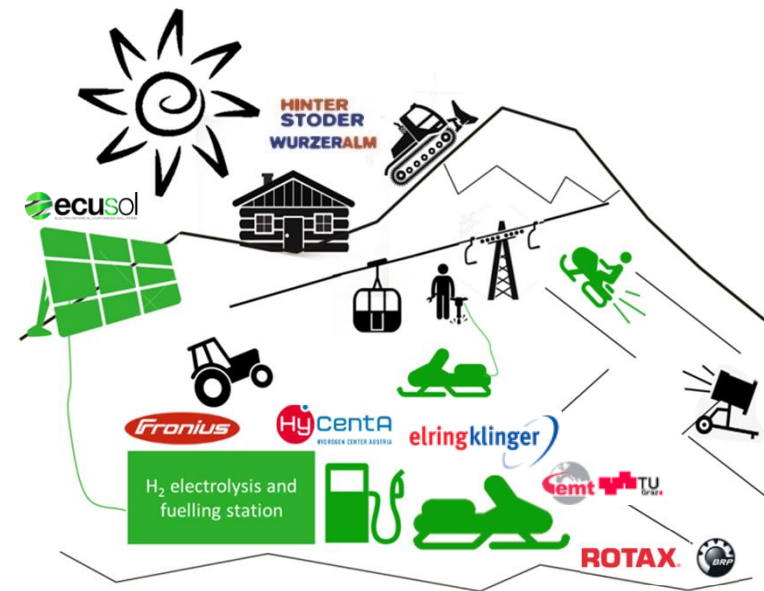

Confidential & Property of the HySnow Consortium

Consortial Partners in HySnow

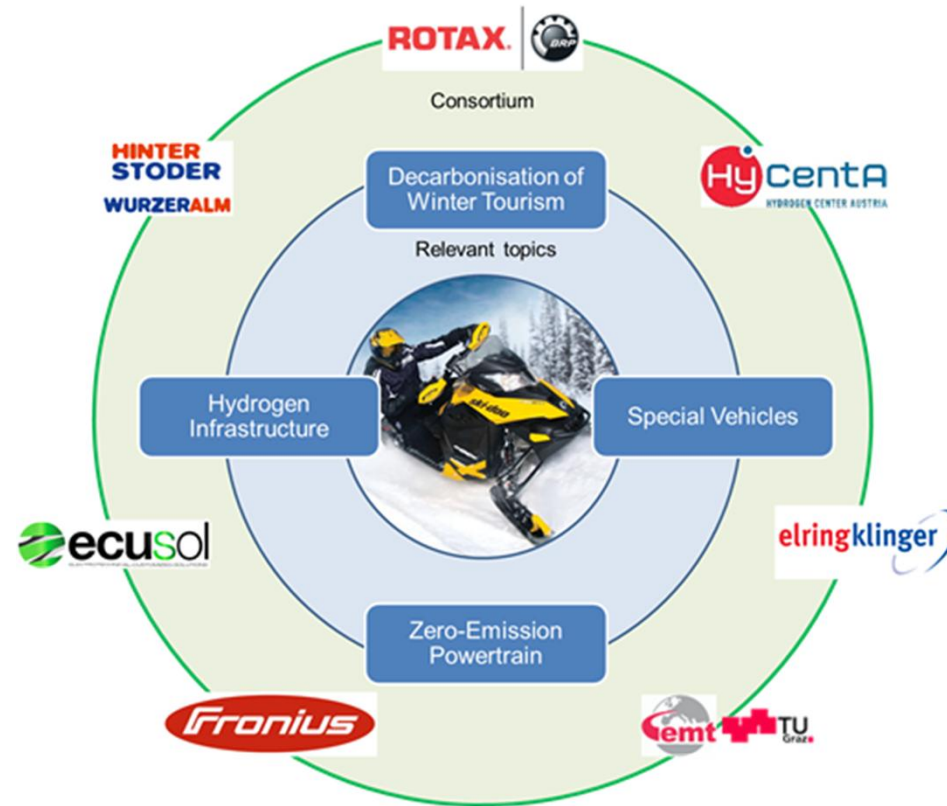

HySnow Achievements



Decarbonisation of Winter Tourism by Hydrogen Powered Fuel Cell Snowmobiles

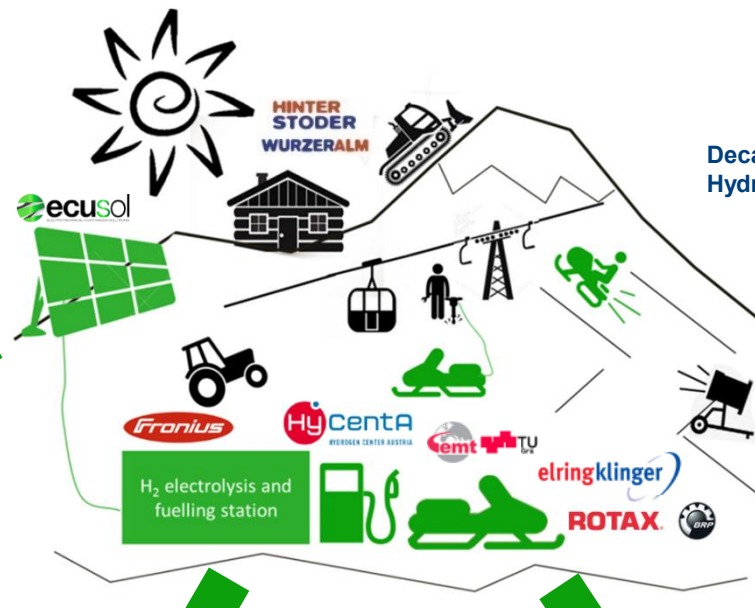

Confidential & Property of the HySnow Consortium

H2 Infrastructure

Process Chain

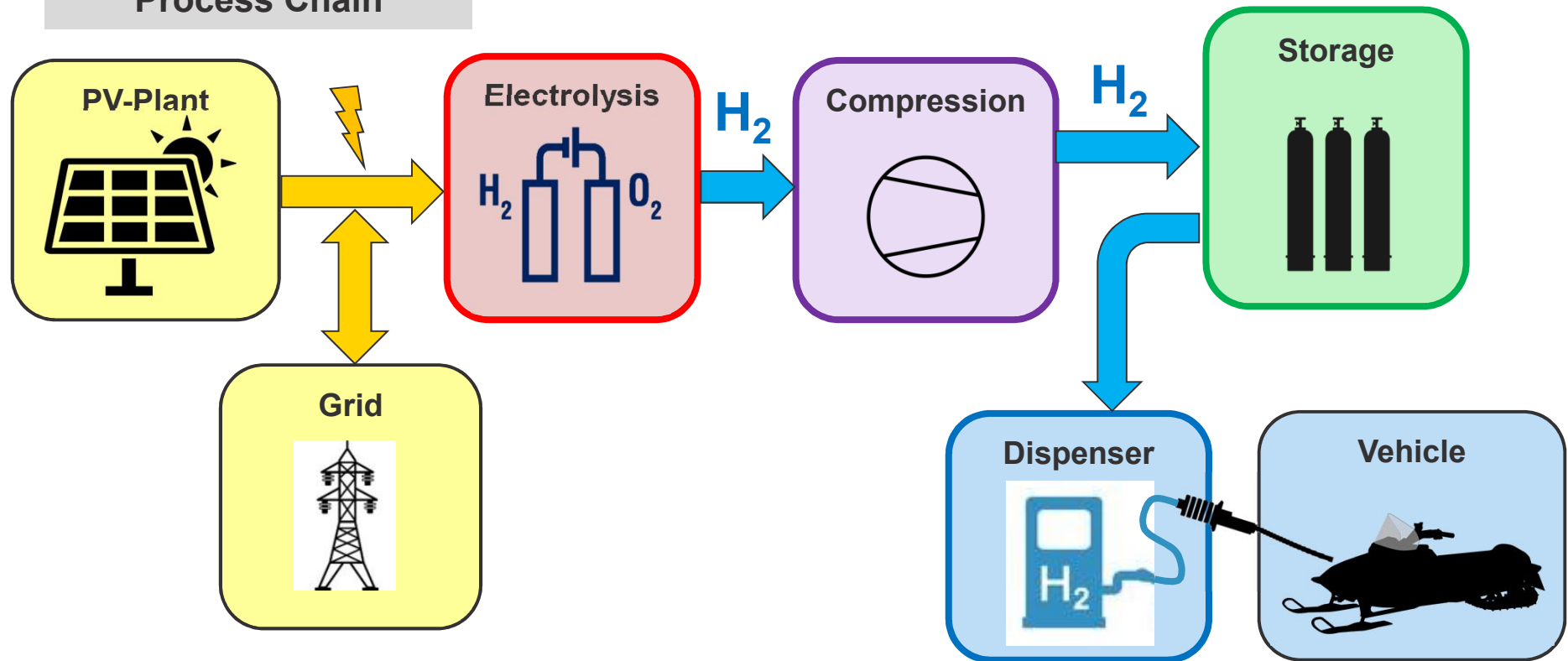

Hydrogen Infrastructure

Infrastructure in test operation



Confidential & Property of the HySnow Consortium

Fuel Cell Powertrain - Layout

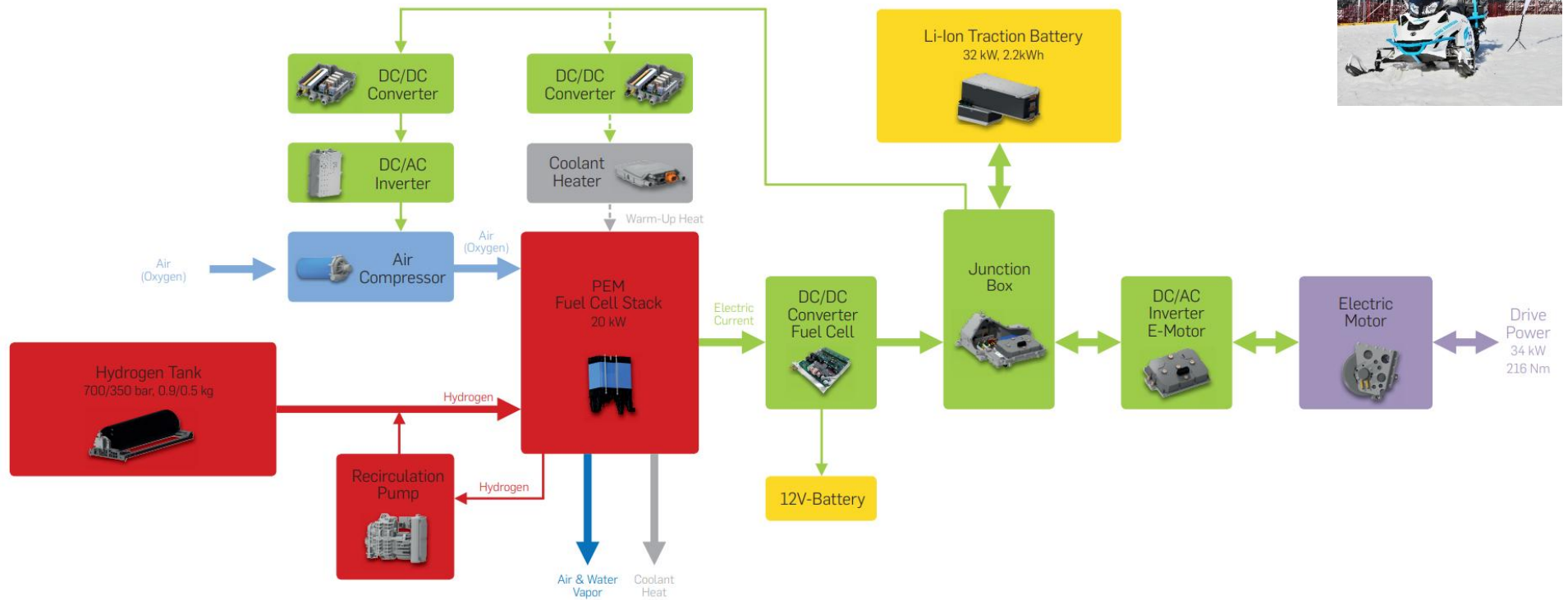



Field Testing at Skiing Area Hinterstoder-Wurzeralm

Overview: Uphill & Downhill Drive

Drive Duration: 1.5 min
 Max. Vehicle Speed: ~54 km/h
 Max. Inverter Power: ~38 kW
 FC-System Power: 5 kW

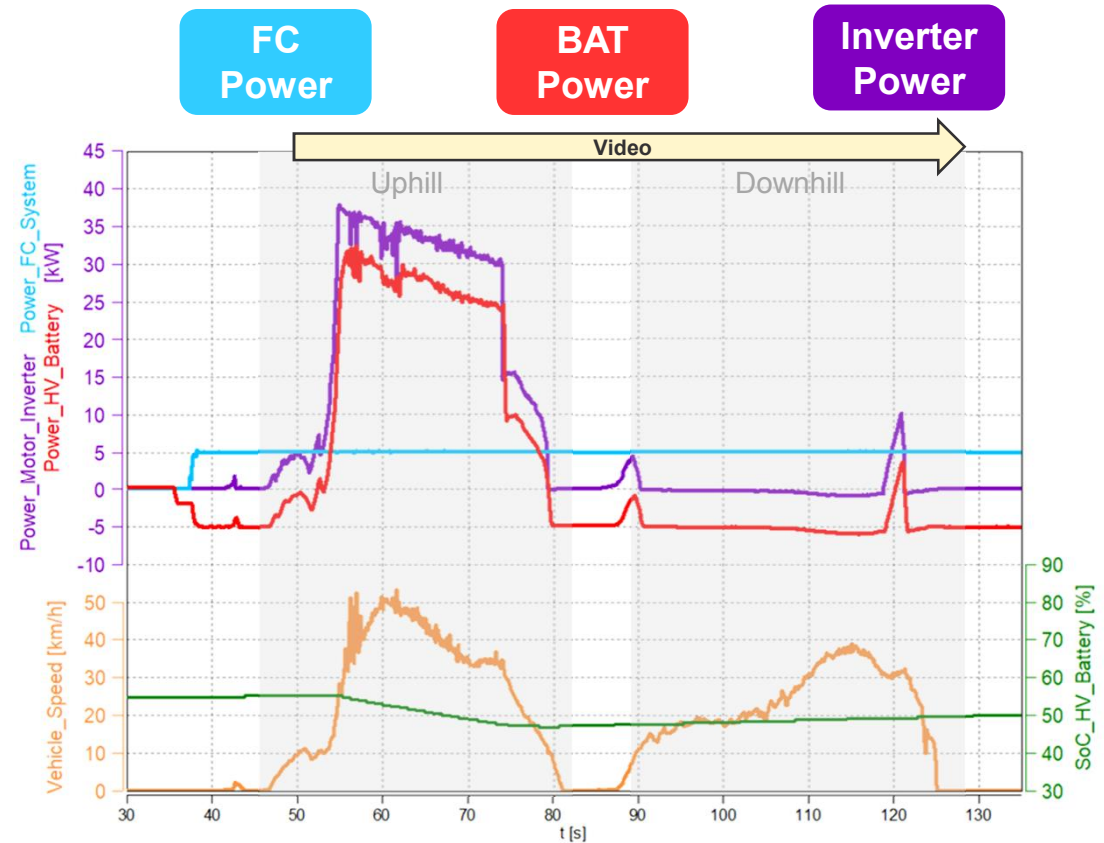
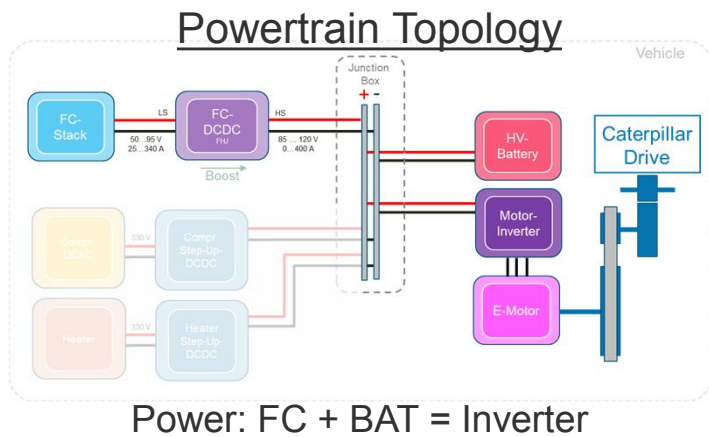

Field Testing at Skiing Area Hinterstoder-Wurzeralm

Uphill Drive

Max. Vehicle Speed: ~54 km/h
 Max. Inverter Power: ~38 kW
 FC-System Power: 5 kW

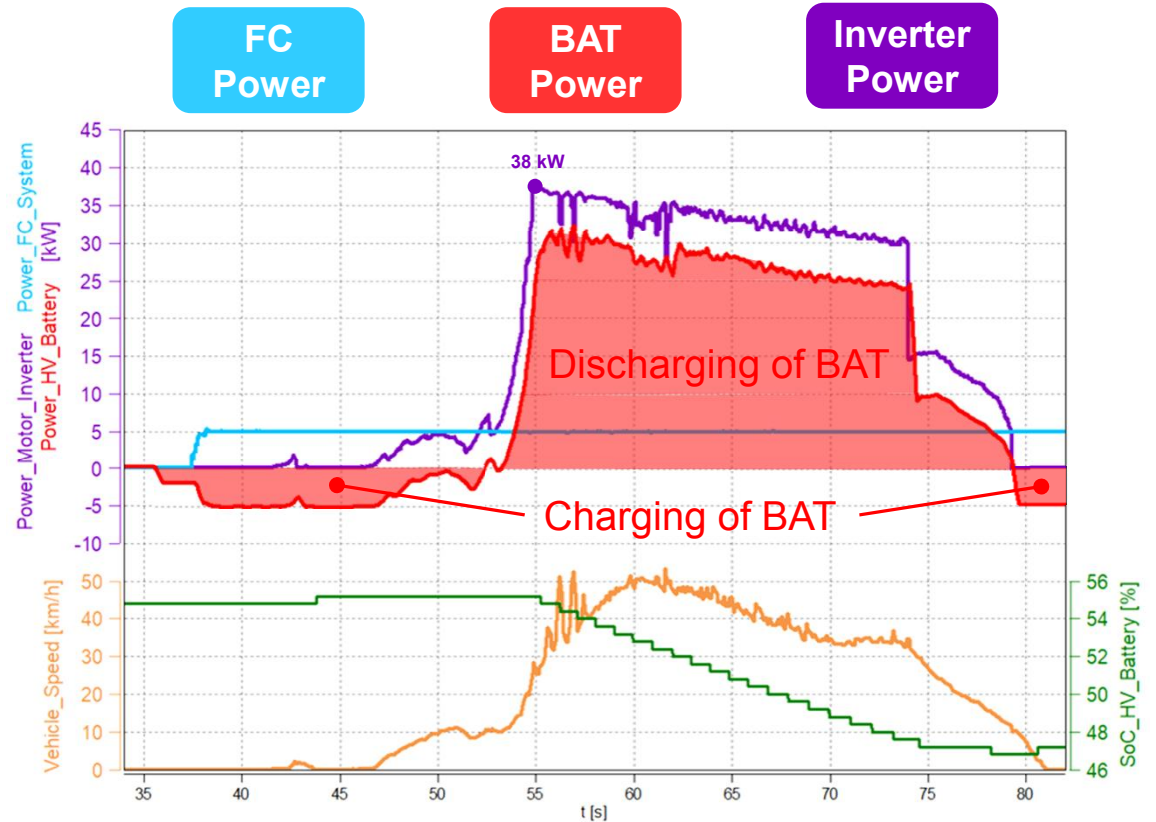
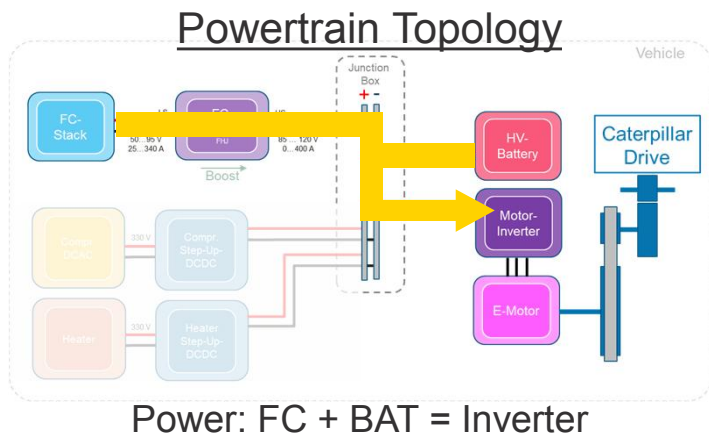

Field Testing at Skiing Area Hinterstoder-Wurzeralm

Vehicle Stop: Charging of HV-Battery with FC

Vehicle Speed: 0 km/h
 FC-System Power: +5 kW
 HV-BAT Power: -5 kW
 Inverter Power: 0 kW

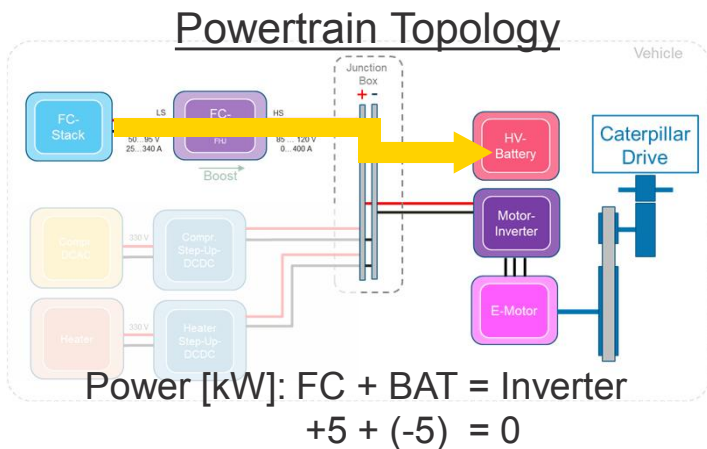

FC Power **BAT Power** **Inverter Power**

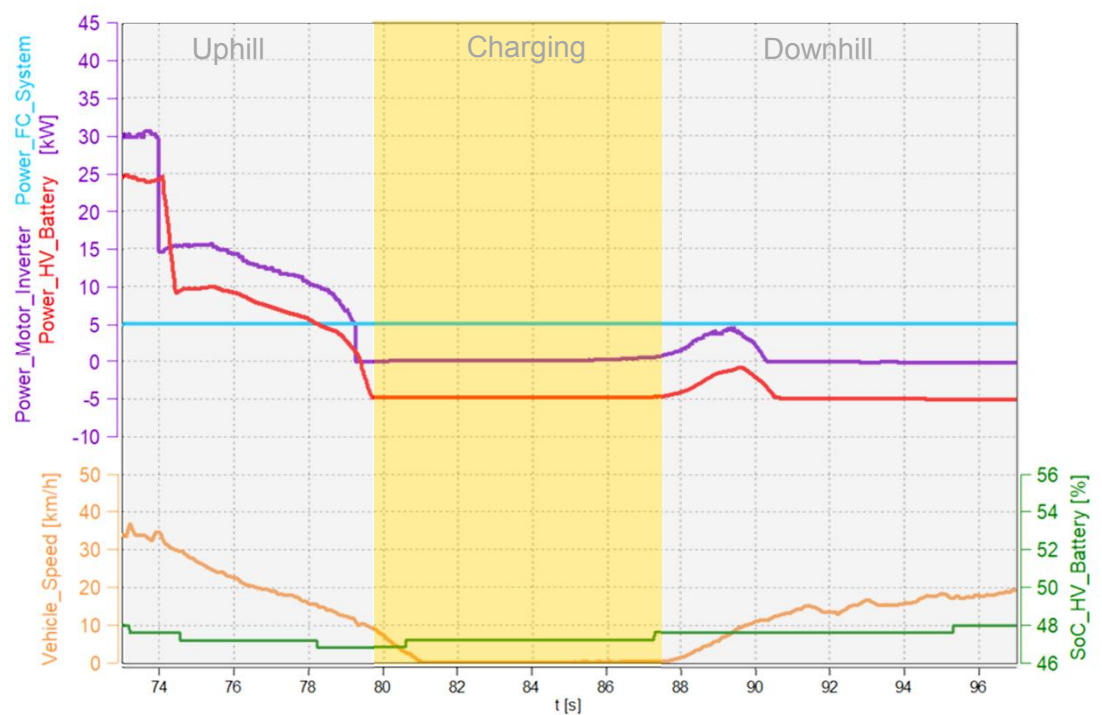

Field Testing at Skiing Area Hinterstoder-Wurzeralm

Downhill Drive: Recuperation

Duration: 15 s

Recuperation Power: ~1 kW (max. 8 kW)

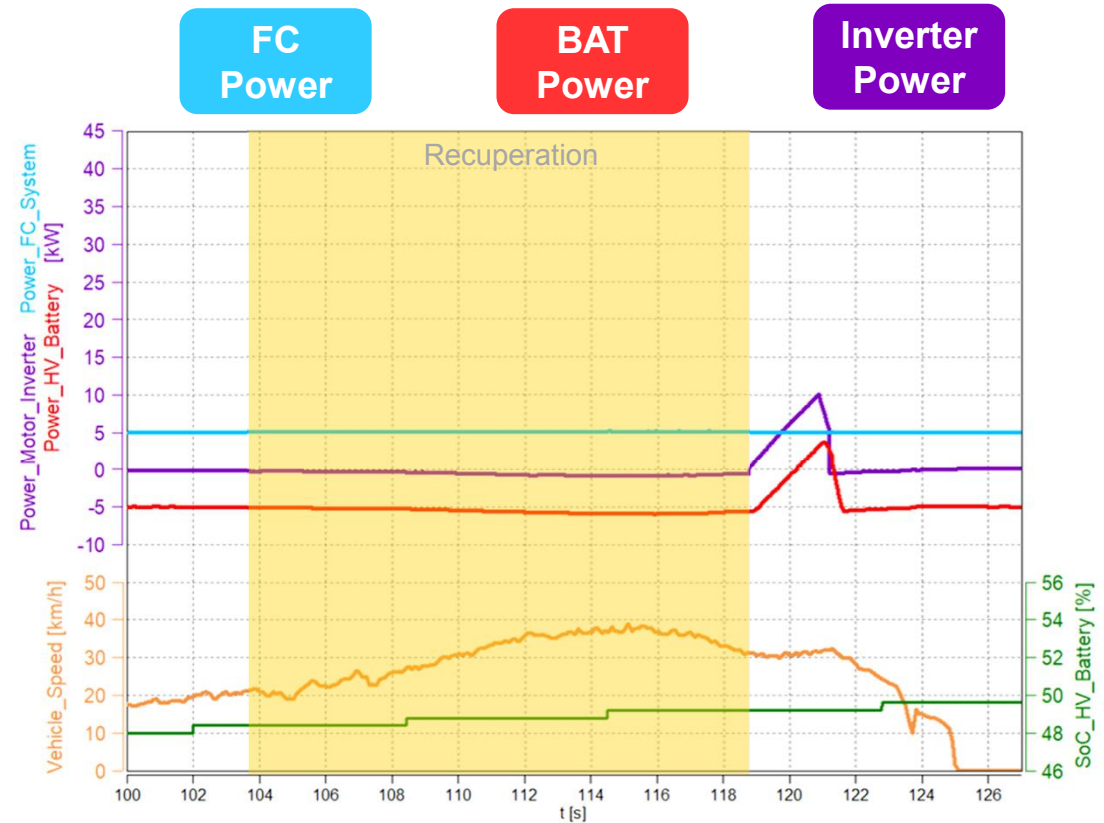
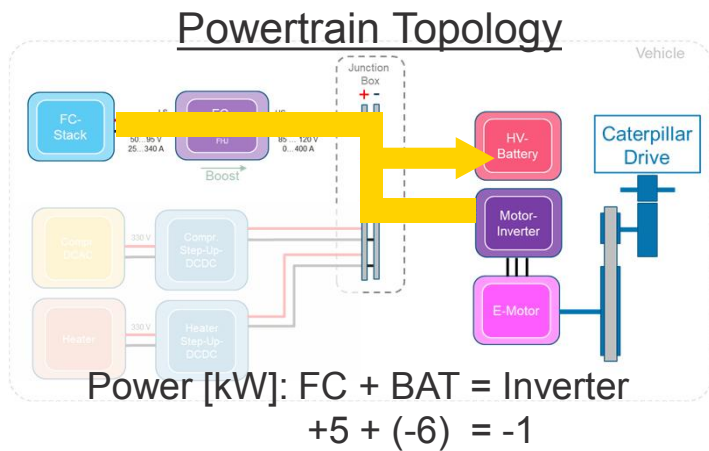

HySnow Presentation – Ski World Cup Hinterstoder 2020



Confidential & Property of the HySnow Consortium



Thank you for your attention!

Confidential & Property of the HySnow Consortium