



Motor design of the eVSP - a milestone in zero-emission-shipping

Linz Center of Mechatronics – Hubert Mitterhofer

CO₂ per ton-mile:

-40% until 2030

-70% until 2050

[Base: 2008, European commission: EU Strategy „Emission reduction in shipping sector“]

Shipping:

1 076 million tonnes of CO₂

=

2.9% of man-made CO₂ emissions

[European commission, 2018]

Aviation:

920 million tonnes of CO₂

=

2.4% of man-made CO₂ emissions

[Environmental and Energy Study Institute, 2019]

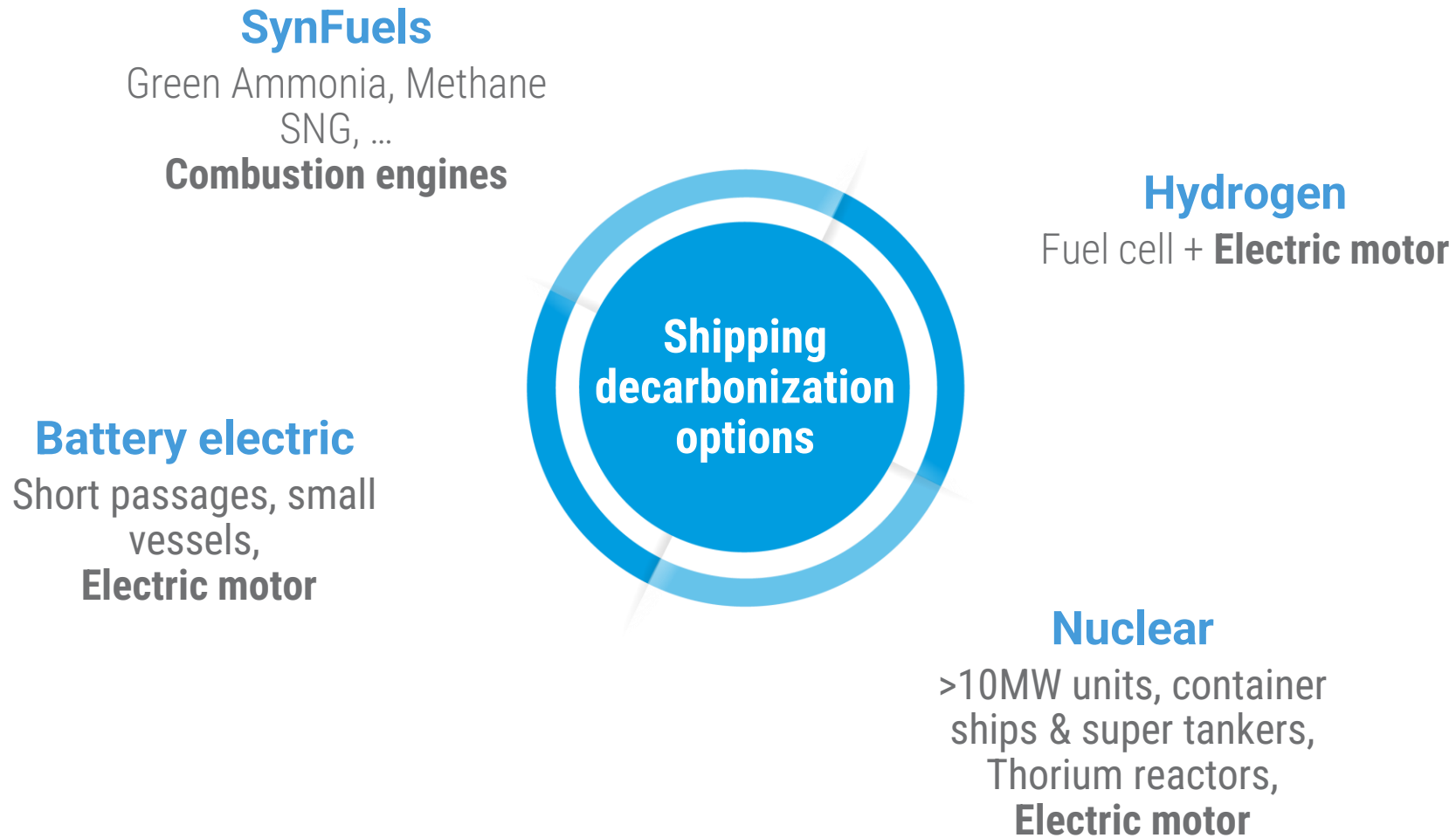

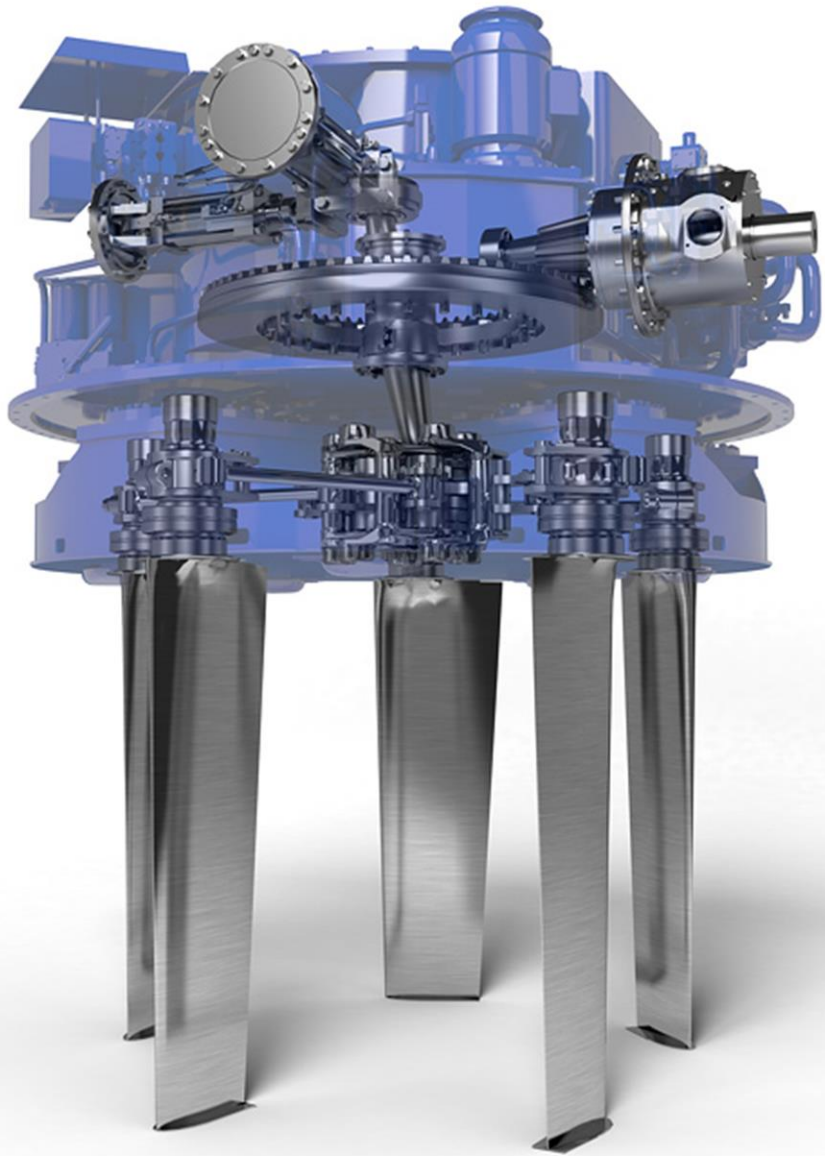

Voith Schneider* Propeller VSP

Highest thrust direction dynamics

Superior maneuvering

Ship stabilization



VSP

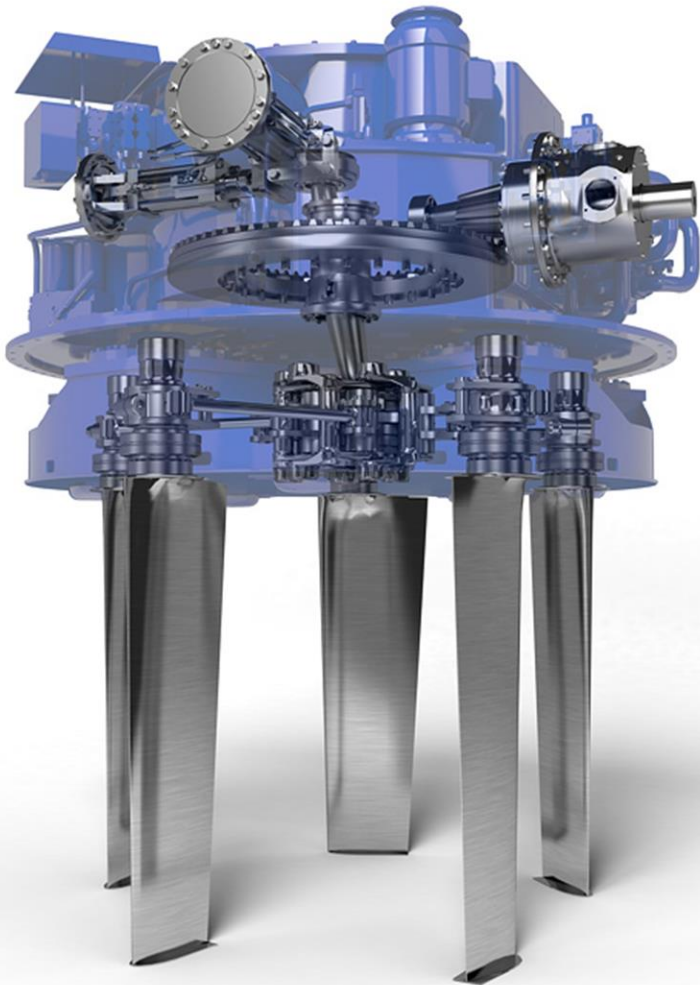

VOITH



ELIN
Motoren
A Voith Company

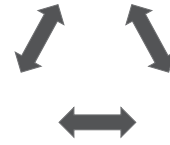

LEM LINZ
CENTER OF
MECHATRONICS

eVSP

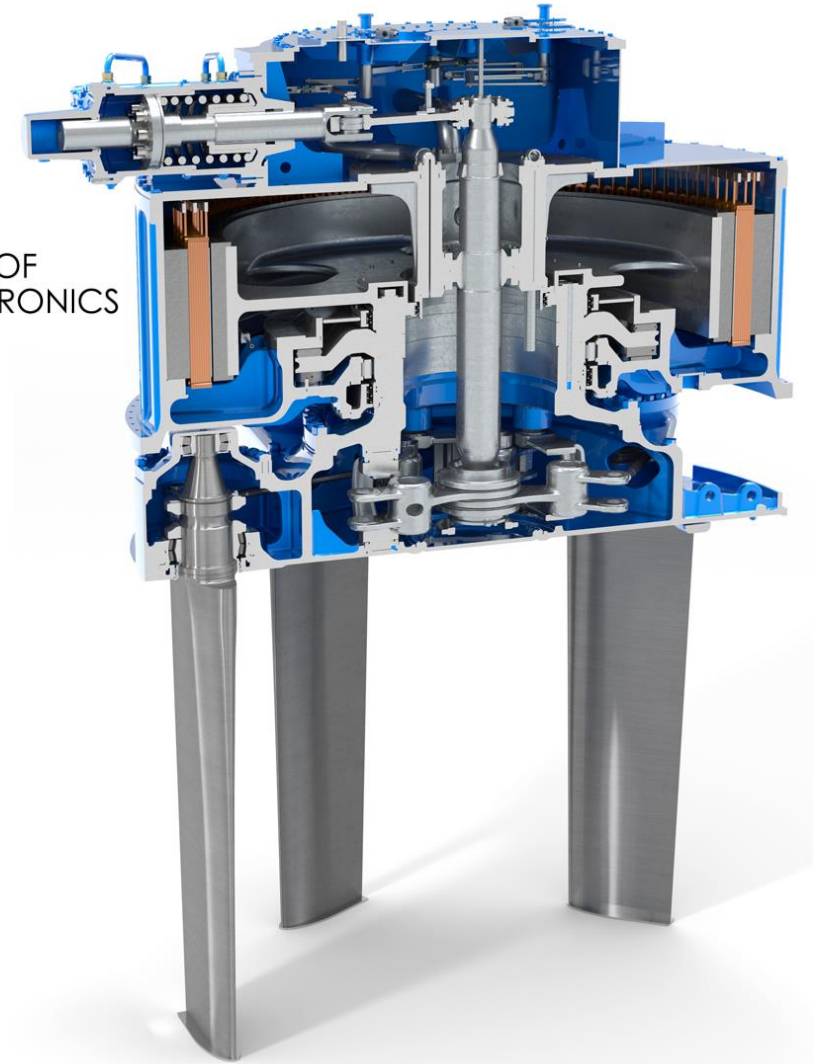

Challenges

- High torque direct drive
- Integration, limited space
- Reduced noise & vibration
- High efficiency, mainly partial load
- Long lifetime, robust system

VSP

VOITH

eVSP

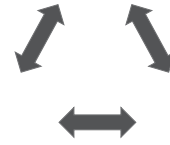
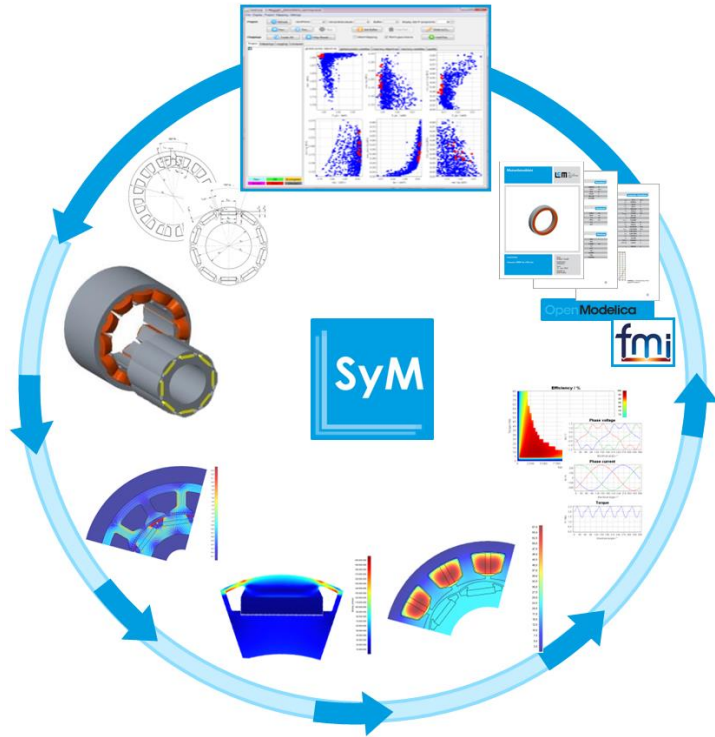

Solution

- Embedded PMSM
- Detailed electromagnetic, thermal & mechanic simulation
- Multi-objective, multi-physics optimization to achieve
 - 212kNm, 1.8MW
 - Efficiency: + 4-12%
 - No demagnetization, $T_{OT} < 60^{\circ}K$

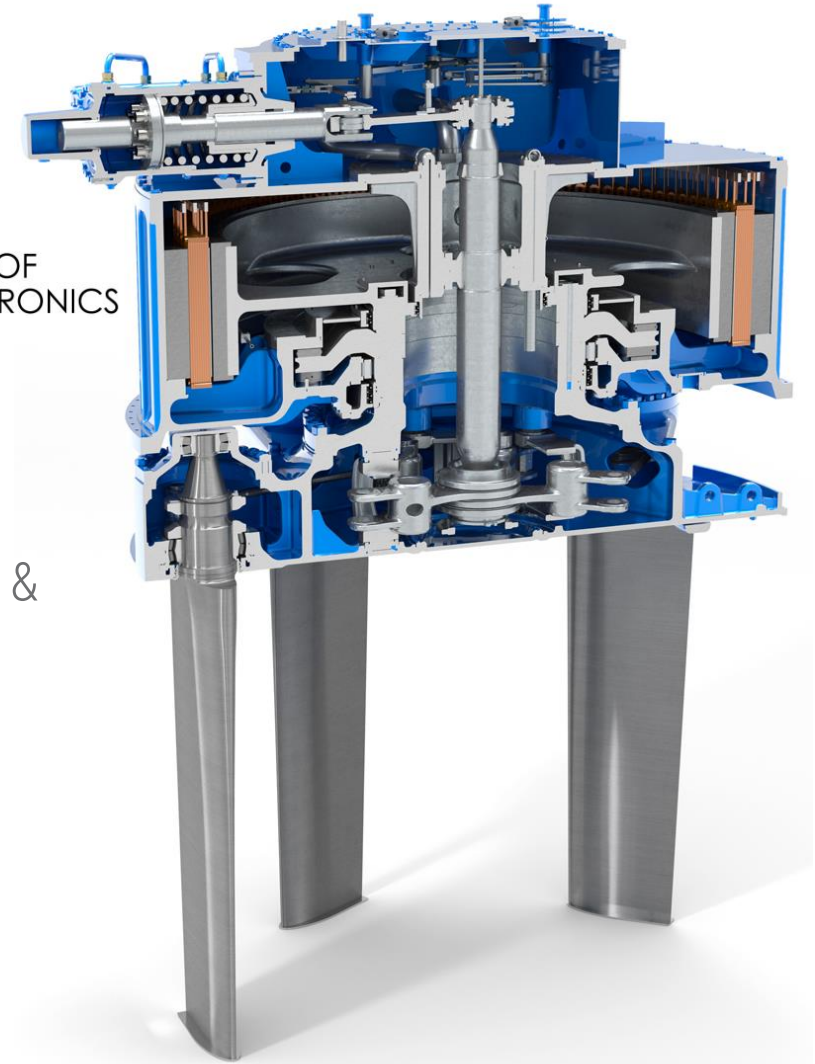

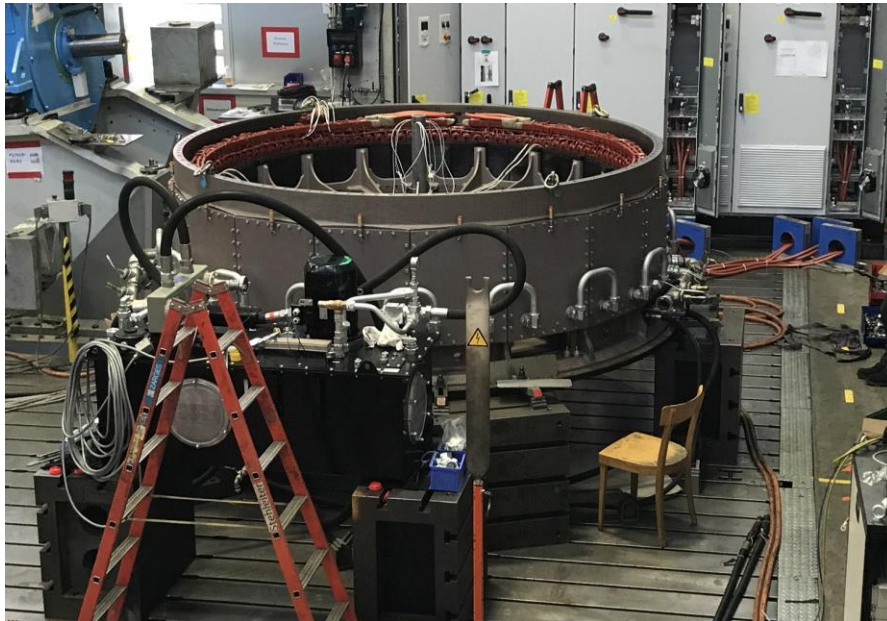

Science becomes reality

#2 of 8

42 eVSP units ordered

45 M€ sales volume

Target: 20 ships / year



Ship owner:

Comparable ship: **10-12to** MDO

edda wind: **3-4 to** MDO

