

POWERTRAIN TRANSFORMATION

CO₂ REDUCTION MEETS FUN-TO-DRIVE

Dr. Harald Naunheimer

Vice President Future Products Magna Powertrain

EVOLUTION OF FUN-TO-DRIVE

What is Fun-to-Drive?



SCALING DYNAMICS AND CO₂

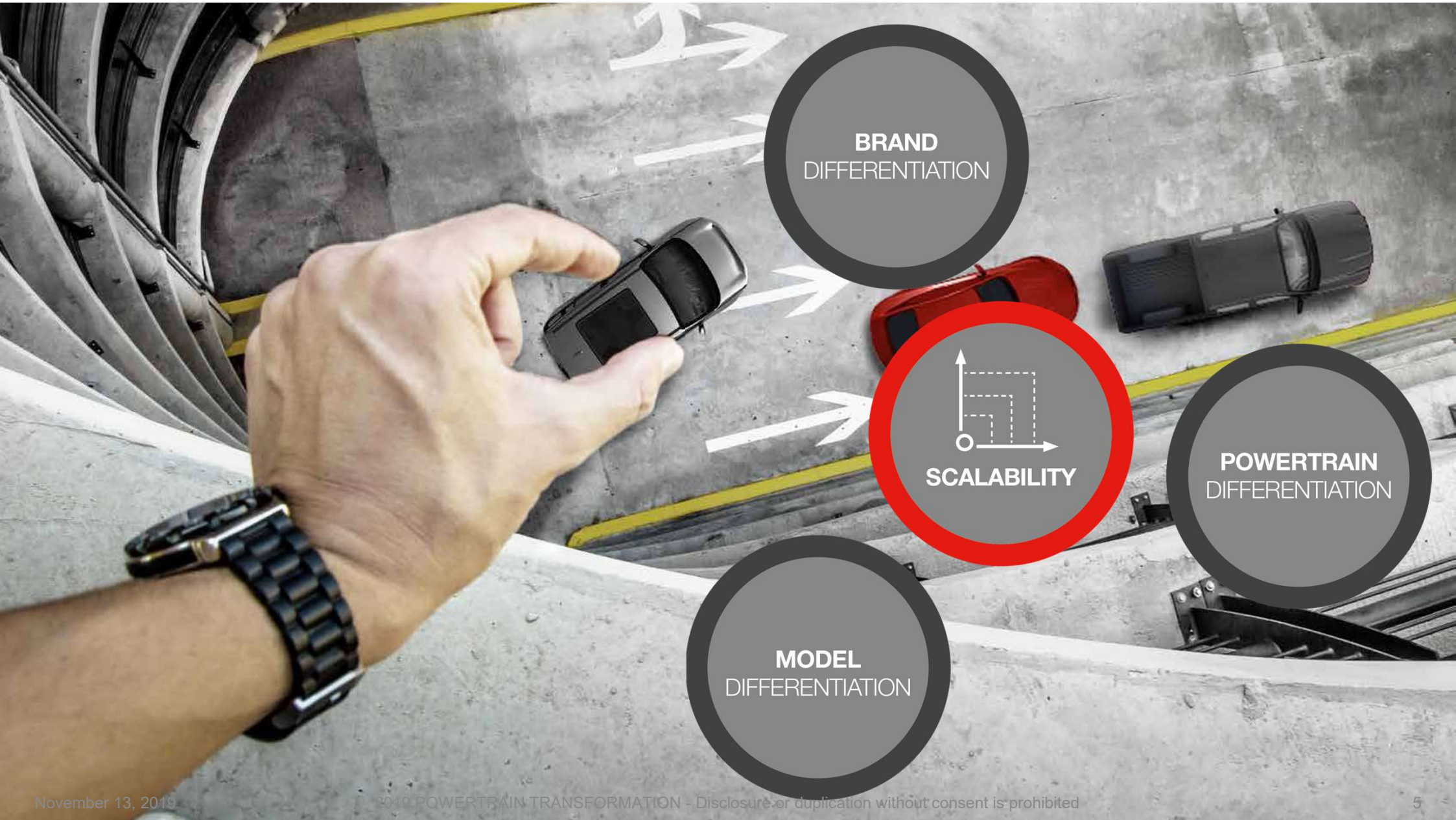

**BRAND
DIFFERENTIATION**

SCALABILITY

**POWERTRAIN
DIFFERENTIATION**

**MODEL
DIFFERENTIATION**

Vehicle Dynamics Today

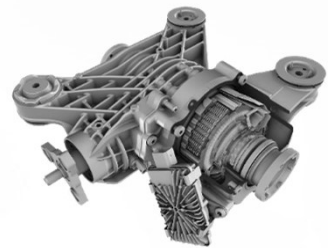

Coupling
Rear Drive Unit

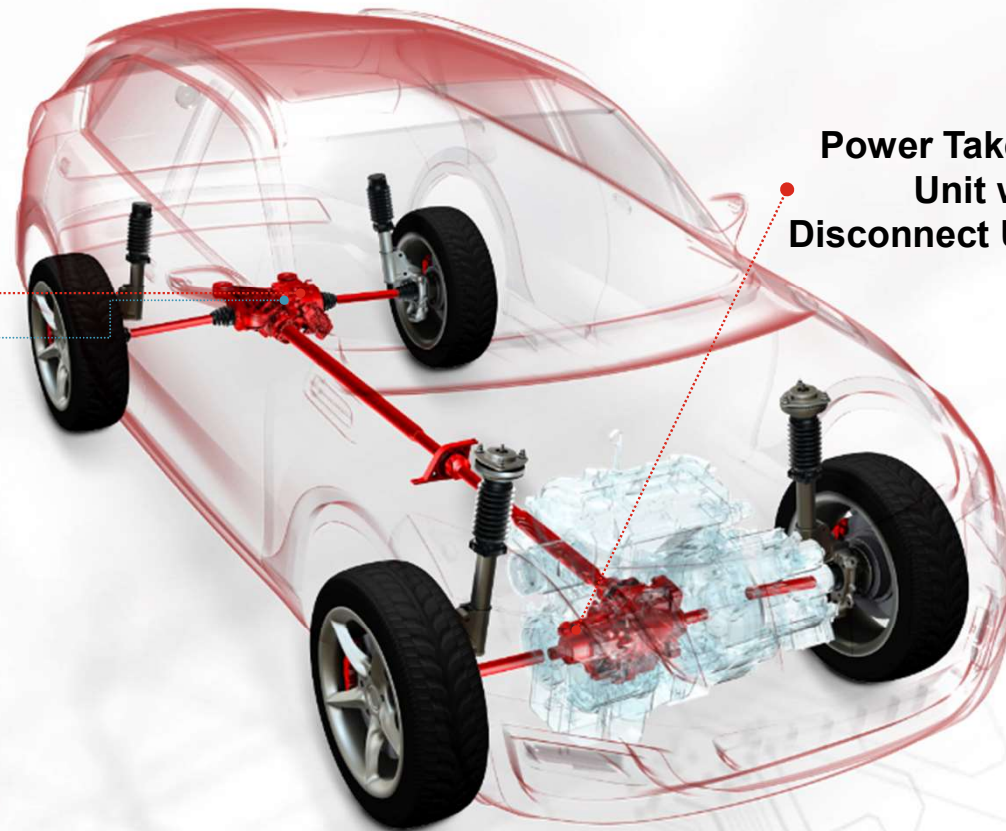

**Power Takeoff
Unit with
Disconnect Unit**



E-Motor – the Key for Scaling Efficiency and Power



Scalability shifts from ICE to e-motor

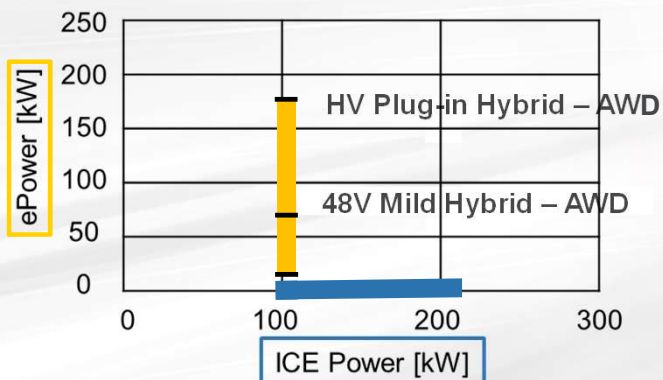

Modular & Scalable Platform

Transmission Systems



Capabilities

DCT family
HDT family
DHT

Driveline Systems



Capabilities

Full AWD/4WD portfolio
e-drives

OEM Benefit

- Reduced complexity
- Scalable functions
- Diversified OEM branding
- Package advantage
- High re-use of content

Base Architecture Conventional ICE DCT

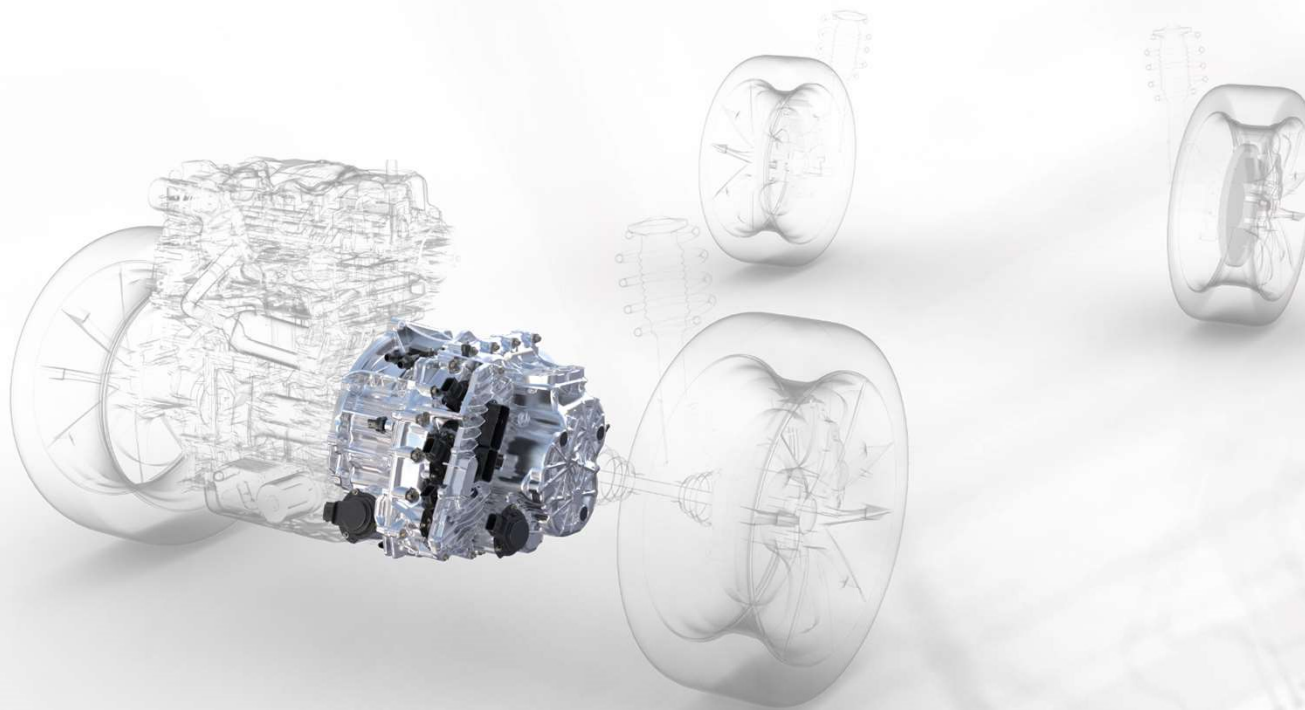

Longitudinal Dynamics

Lateral Dynamics

CO2 Improvement

Hybrid Scalability: 48V HDT P2.5

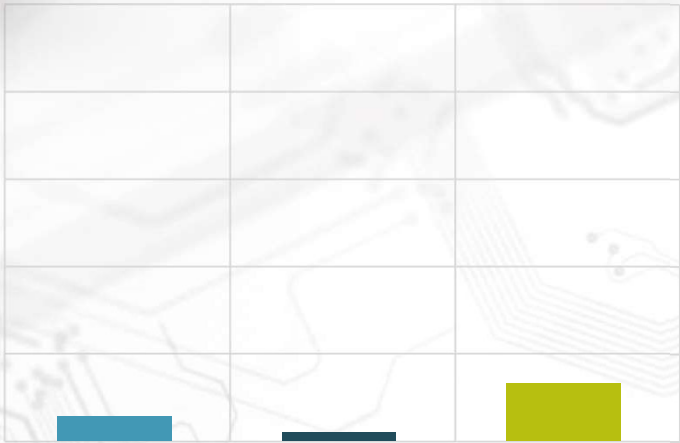
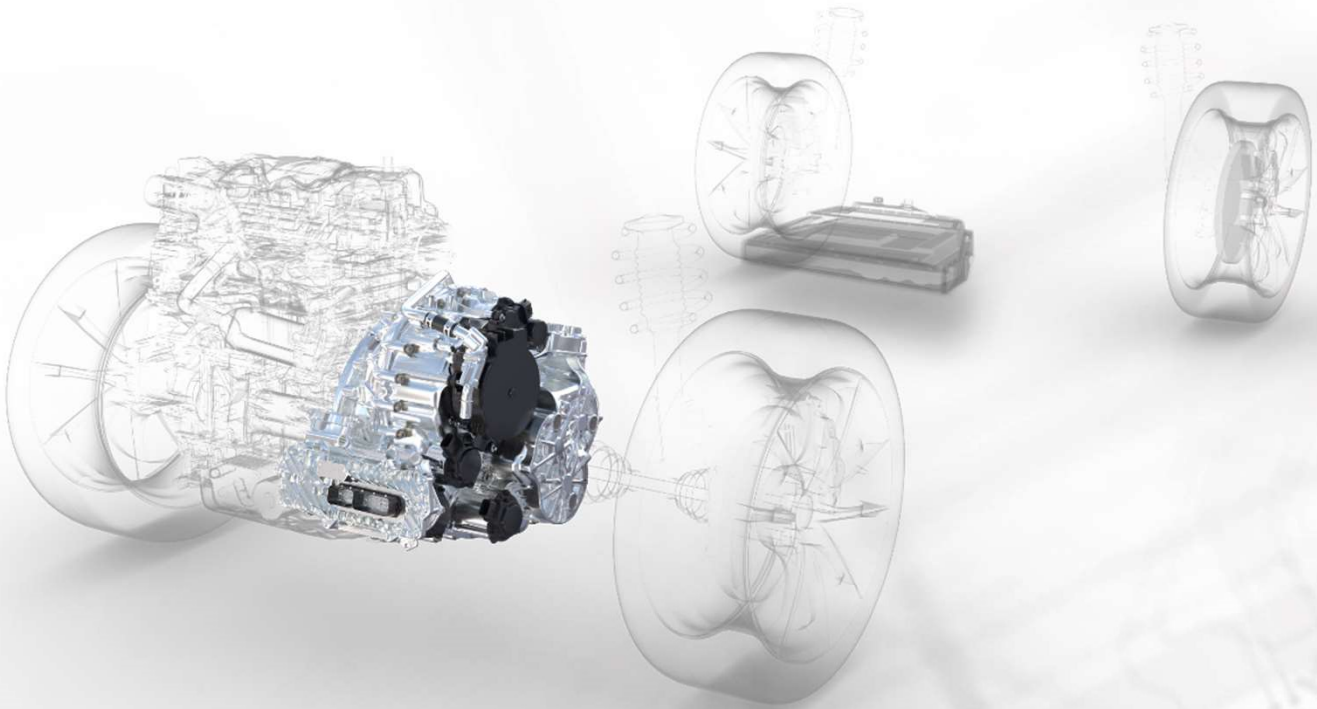

Longitudinal Dynamics

Lateral Dynamics

CO2 Improvement

Hybrid Scalability: 48V HDT P2.5+P4

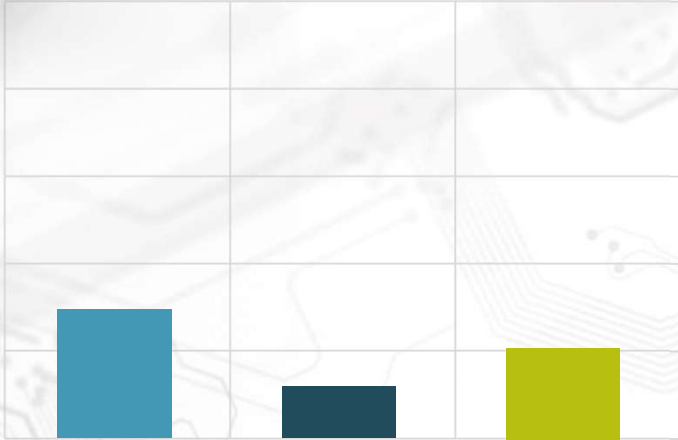
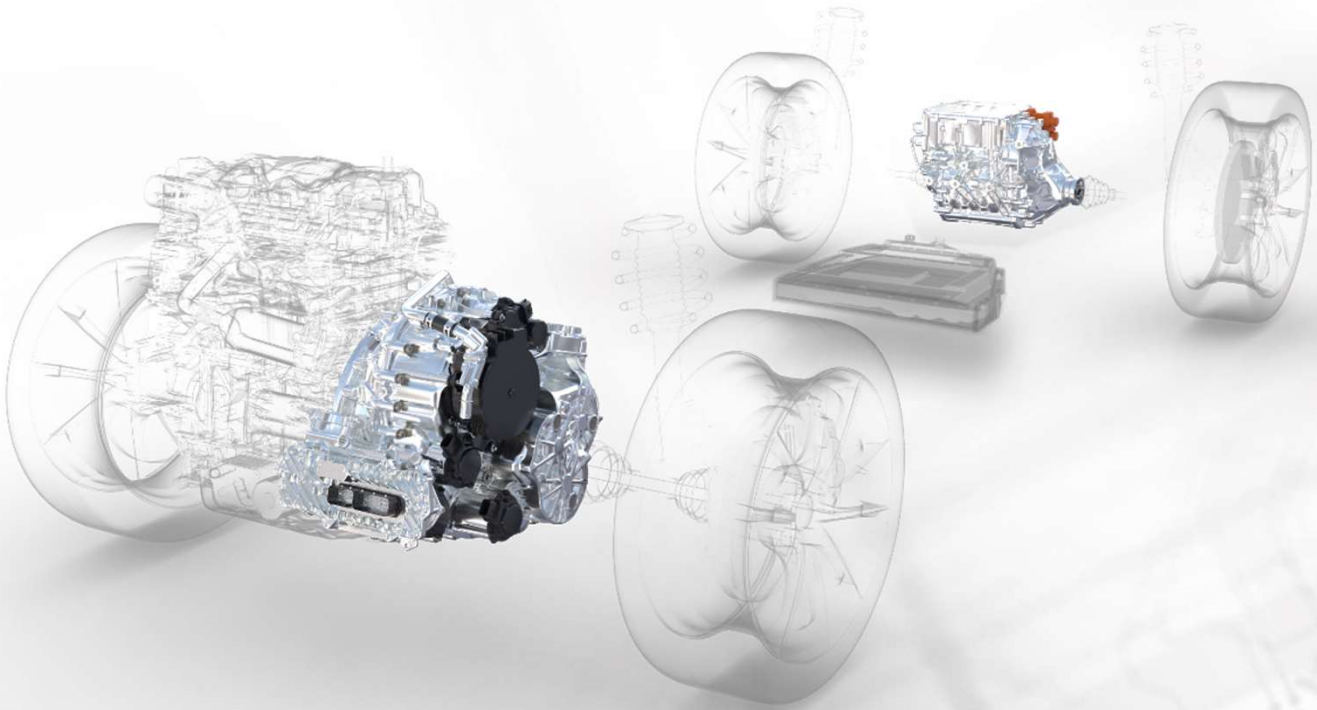

Longitudinal Dynamics

Lateral Dynamics

CO2 Improvement

Hybrid Scalability: PHEV HDT 85 kW P2.5

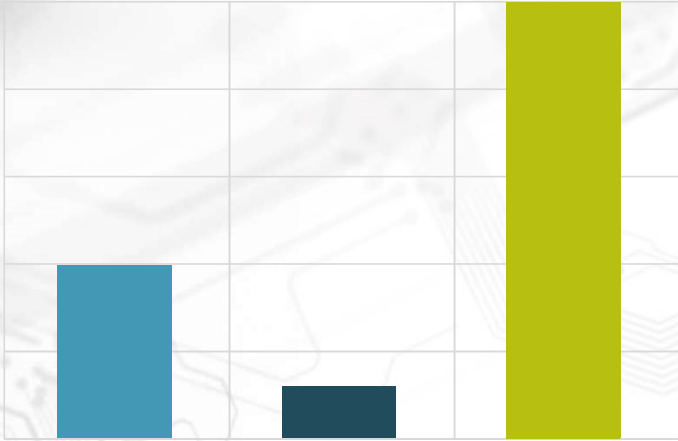
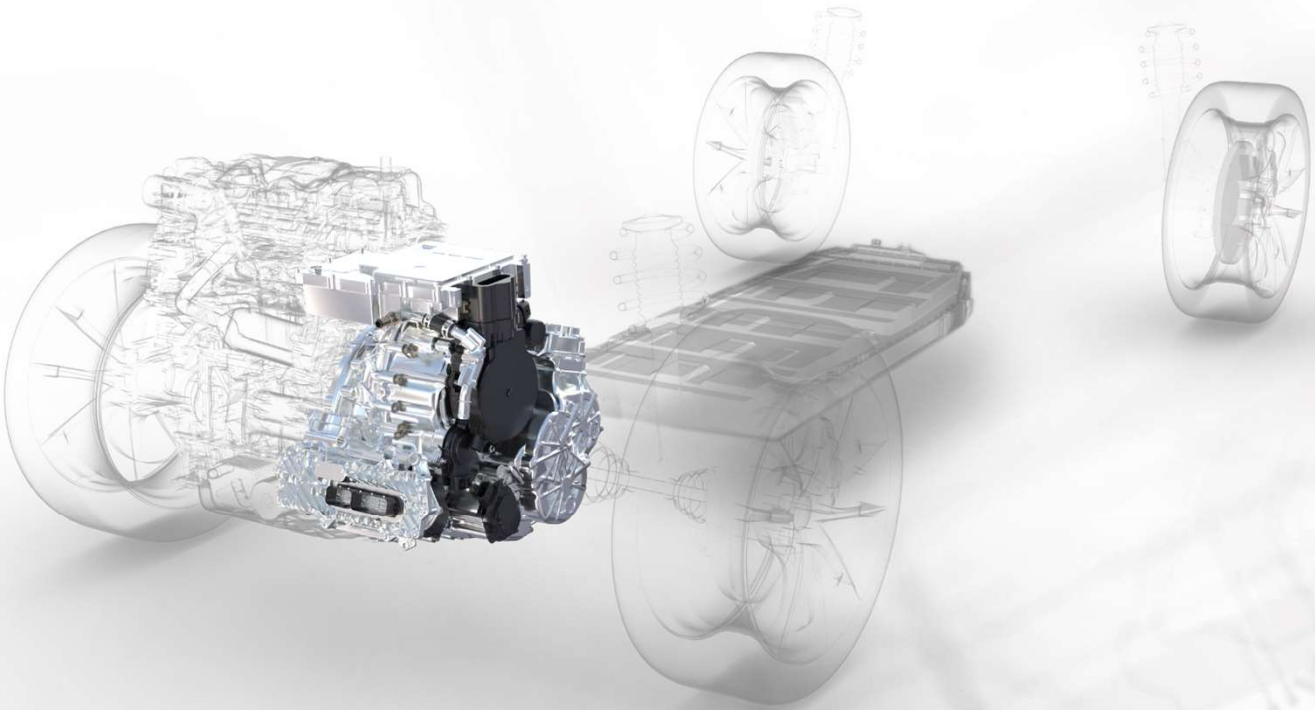

Longitudinal Dynamics

Lateral Dynamics

CO2 Improvement

Hybrid Scalability: PHEV HDT 85 kW P2.5 + 80 kW P4

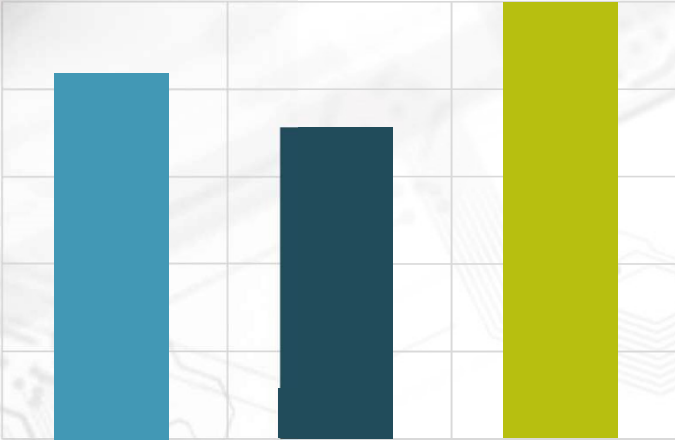
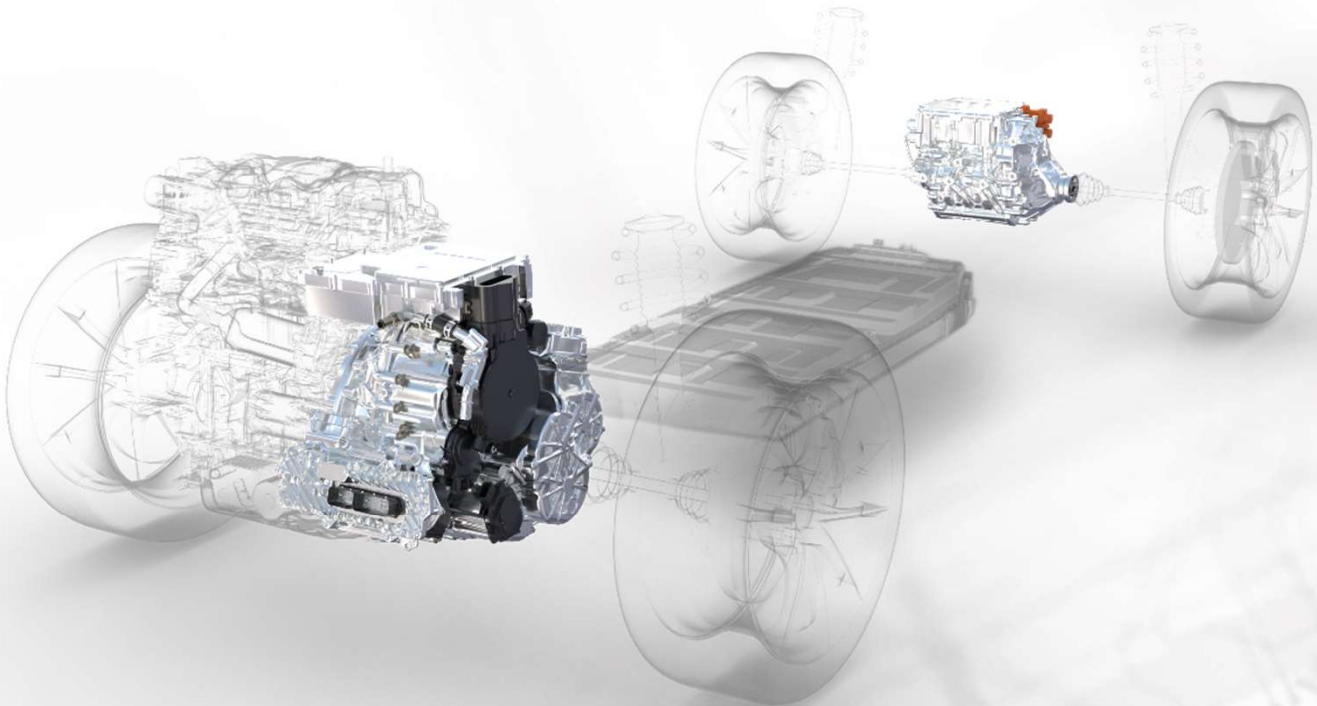

Longitudinal Dynamics

Lateral Dynamics

CO2 Improvement

Hybrid Scalability: PHEV HDT 85 kW P2.5 + 140 kW P4 TV

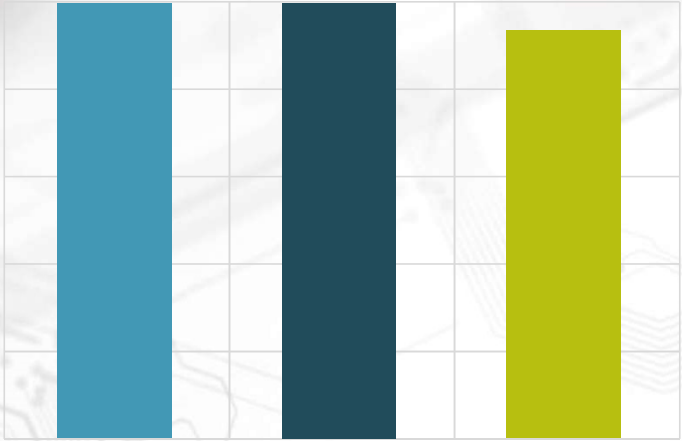
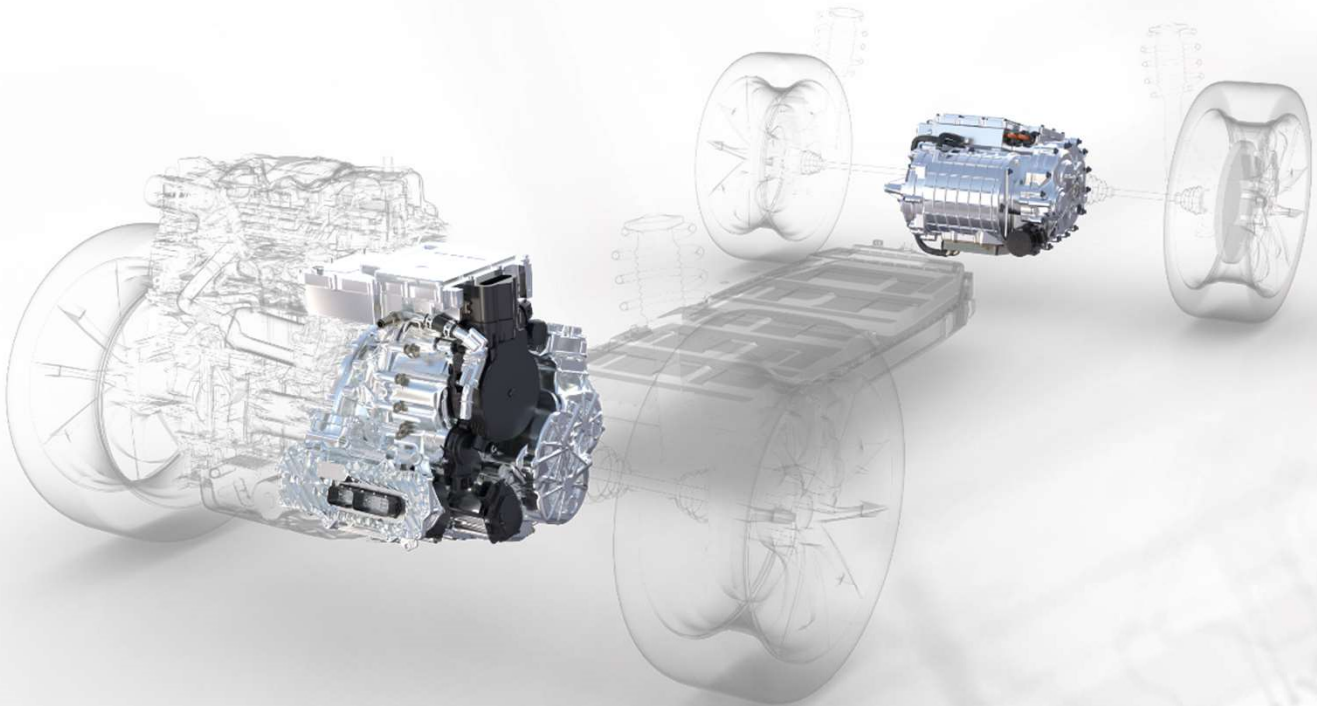

Longitudinal Dynamics

Lateral Dynamics

CO2 Improvement

SCALING THE VEHICLE “DNA”

Scalability Approach

SYSTEM POWER

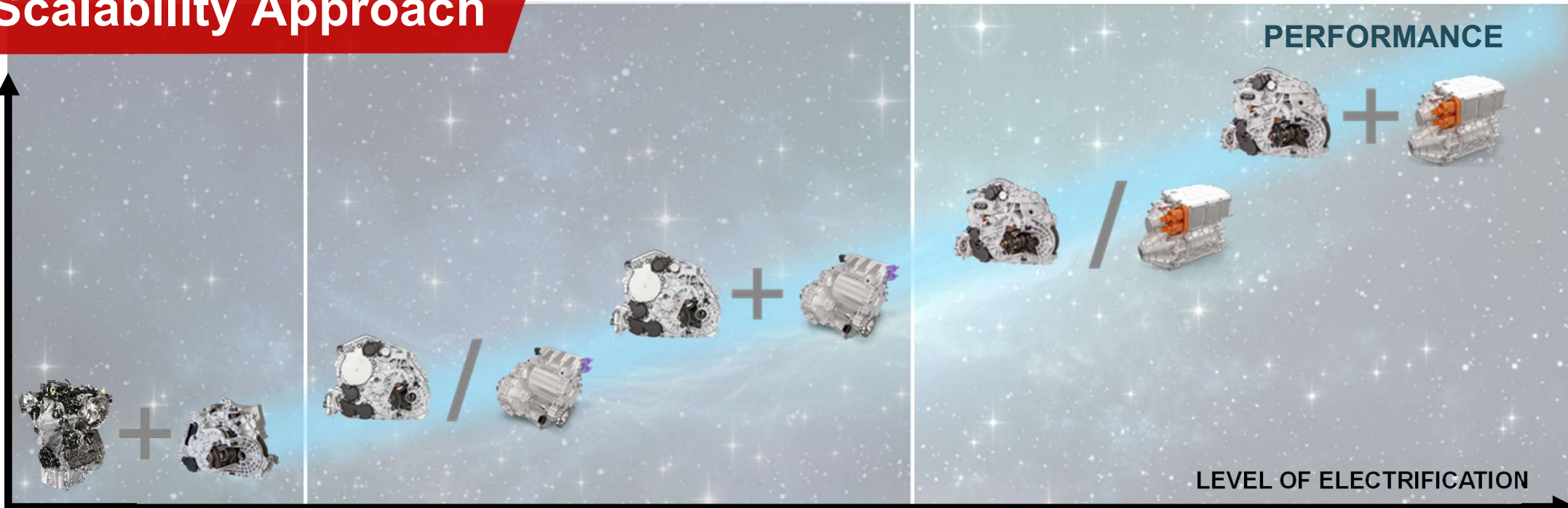

CONVENTIONAL ICE

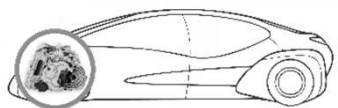

Conventional Combustion Engine
Front-Wheel Drive

48V MILD HYBRID

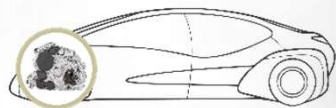

48V Mild Hybrid –
Front-Wheel Drive

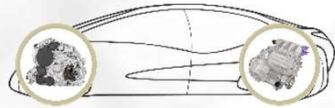

48V Mild Hybrid –
All-Wheel Drive

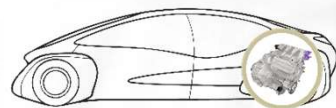

48V Mild Hybrid –
All-Wheel Drive

HV HYBRID

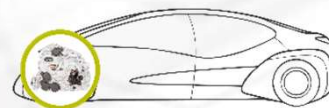

HV Plug-in Hybrid –
Front-Wheel Drive

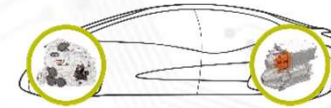

HV Plug-in Hybrid –
All-Wheel Drive

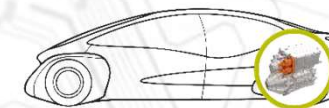

HV Plug-in Hybrid –
All-Wheel Drive

Scalable Modules for Scalable Dynamics and Functions



Scalable Modules for Scalable Dynamics and Functions

Scalability means:

- Scalable functions on the entire vehicle
- Scalable powertrain functions
- Scalable software functionality
- Scalable components performance



Future Vehicle Dynamics

Hybrid Dual Clutch Transmission
High Voltage

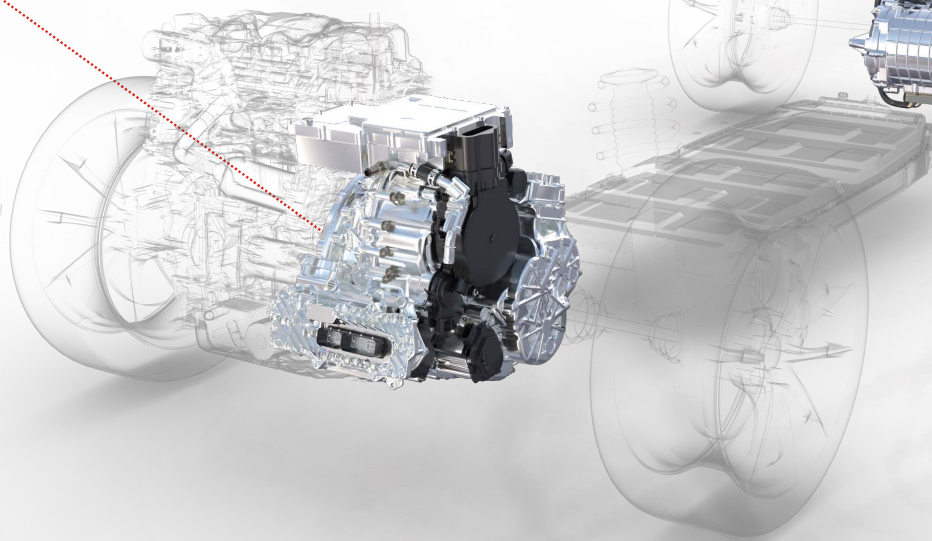

Highly Integrated eDrive Mid
Torque Vectoring

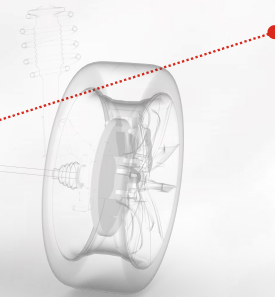

HV Plug in Hybrid All-Wheel Drive Lateral Dynamics

Video

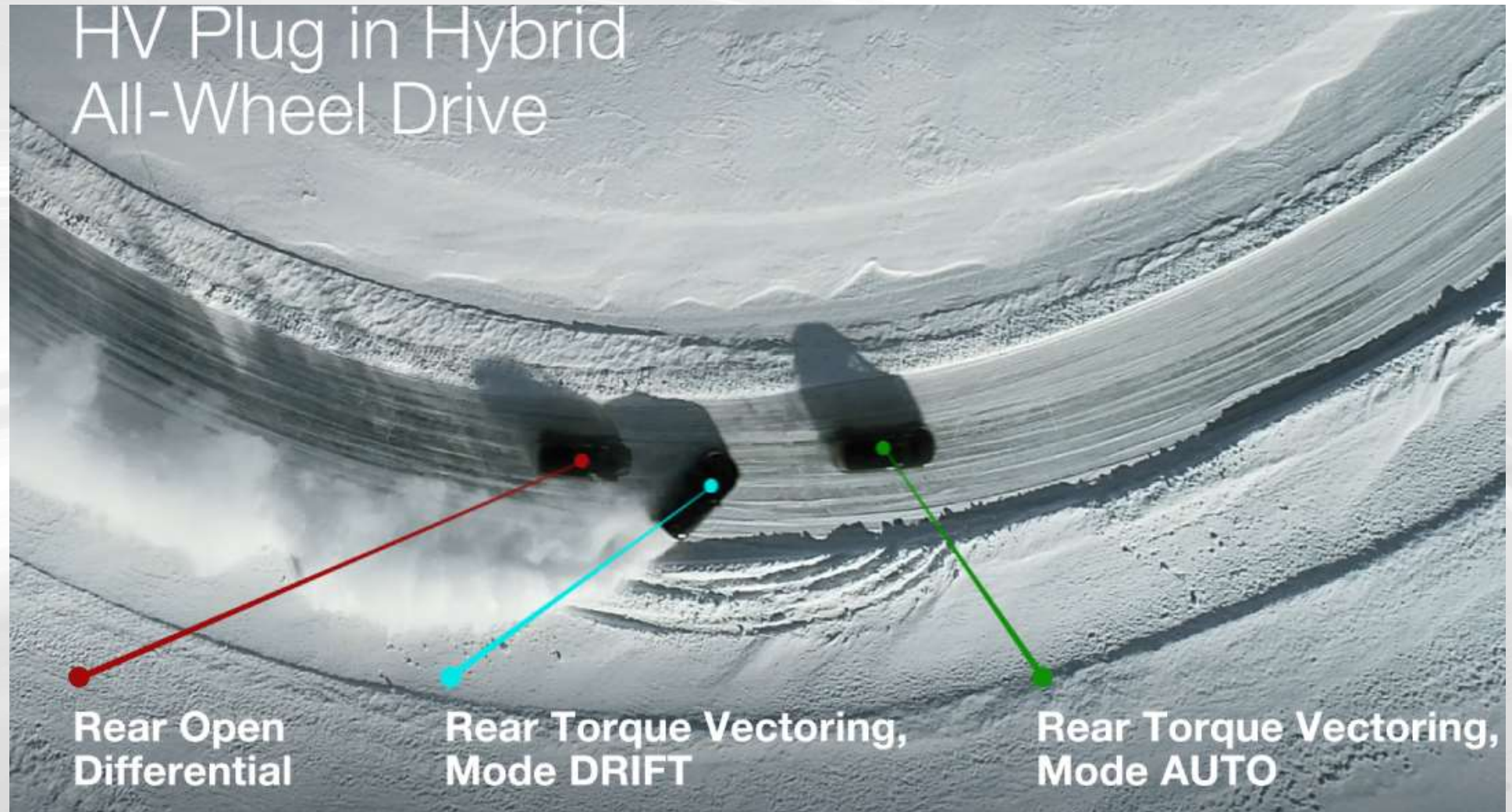

Outlook

- CO2 reduction and high driving dynamics are not mutually exclusive
- “Fun to Drive” is driving dynamics and handling - but not only ...
- Electrification adds comfort, safety, and customizability
- New opportunities for brand and model differentiation by scaling performance and functions
- Besides AWD competence we need integration expertise for the entire electrified powertrain

A huge challenge, but also an opportunity

