



TECHNISCHE
UNIVERSITÄT
WIEN



The Planetary Motor

Design and control of a
novel multi-rotor structure

Manfred Schrödl

Andreas Brunner

Institute of Energy Systems and Electrical Drives

Technische Universität Wien

A3PS Nov. 2017

- Deriving the topology of the Planetary Motor
- Electrical equivalent circuit
- Functional prototype
- Control strategy
- Sensorless INFORM® method
- Applications
- Future work

The Planetary Motor

- 3-phase motor
- 3 single coils
- 2-pole PM rotor

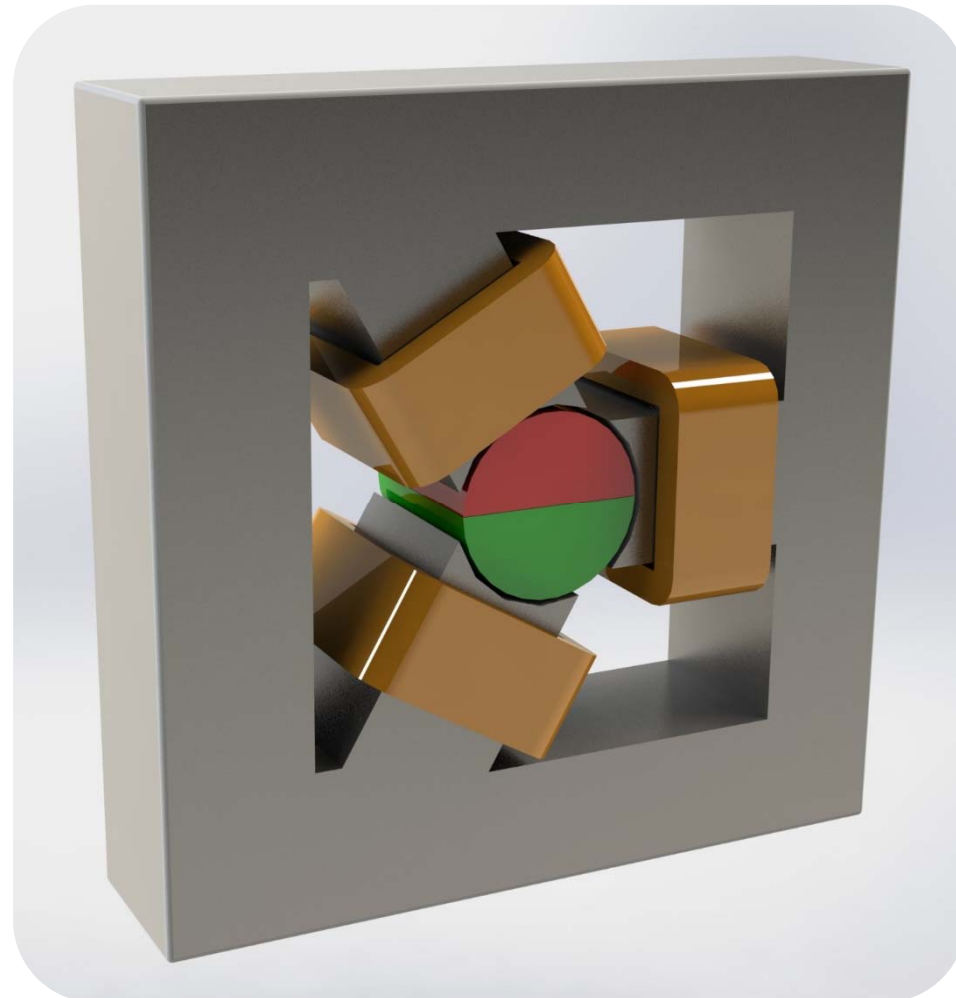

The Planetary Motor

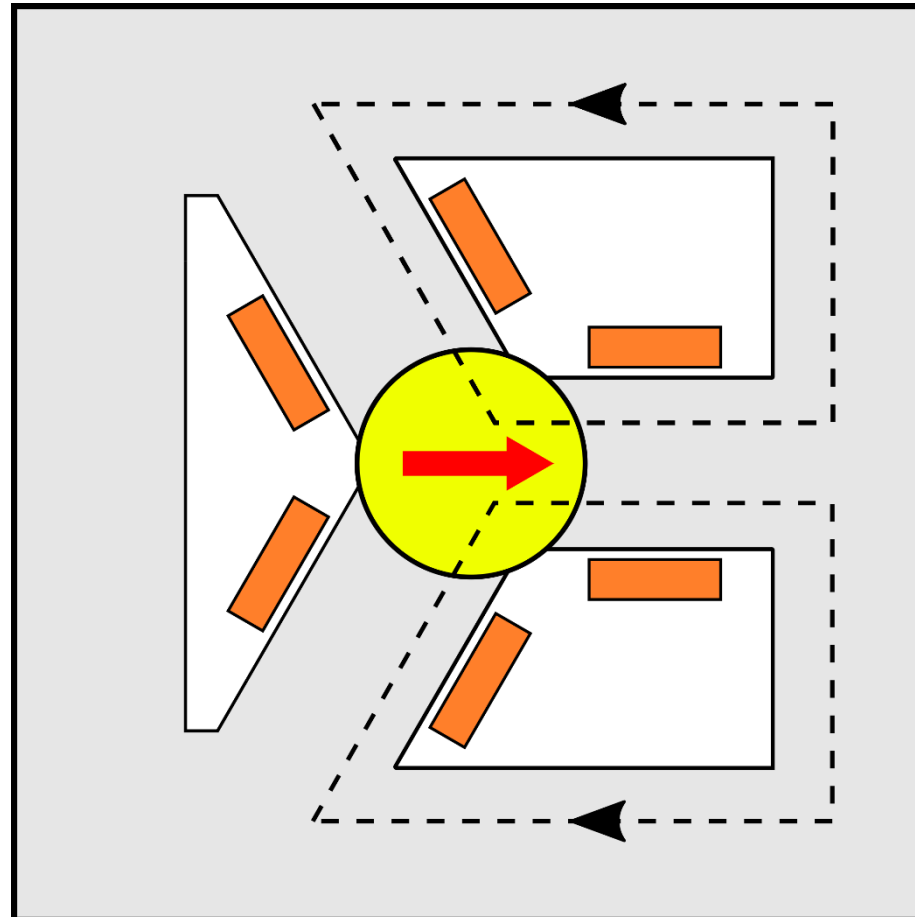

The Planetary Motor

- Arrange 4 equivalent motors symmetrically

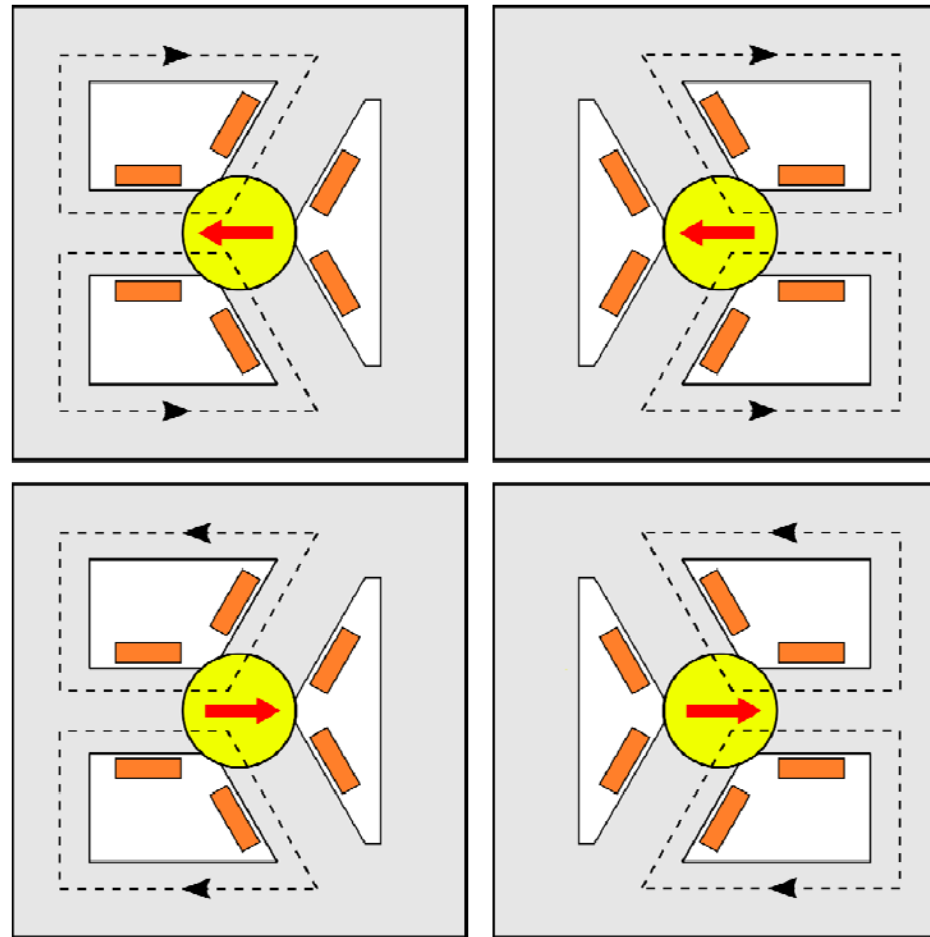

The Planetary Motor

- Combine into single structure

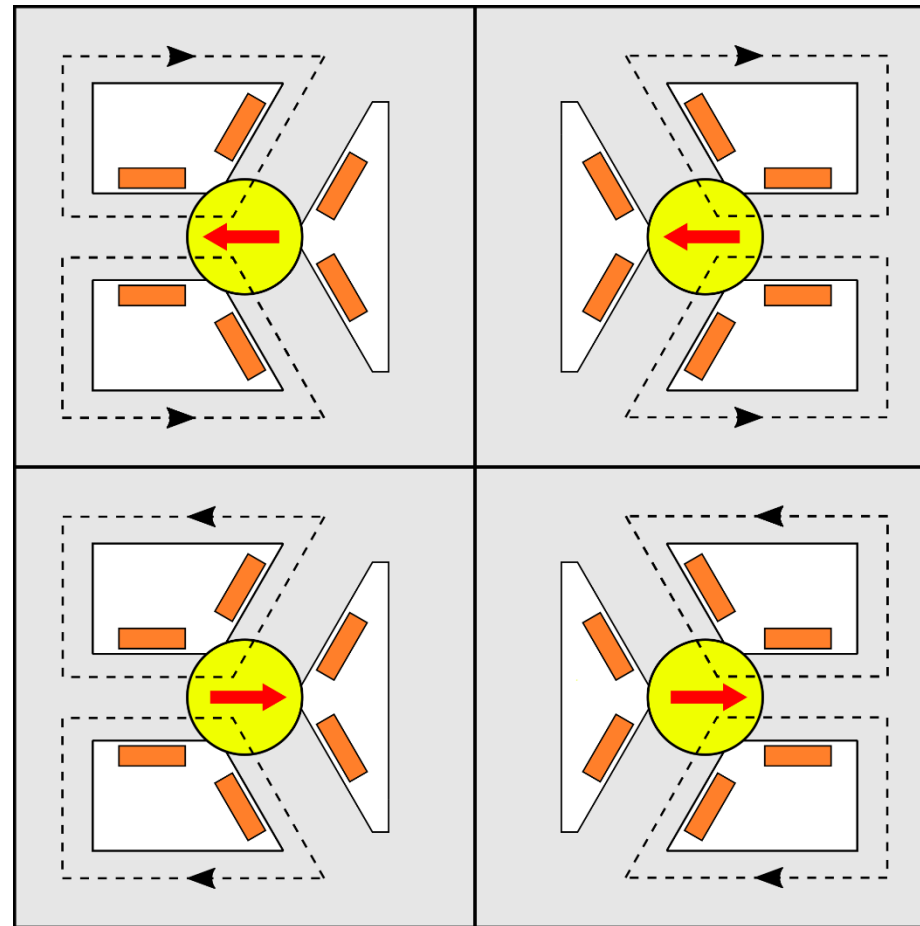

The Planetary Motor

- Combine into single structure

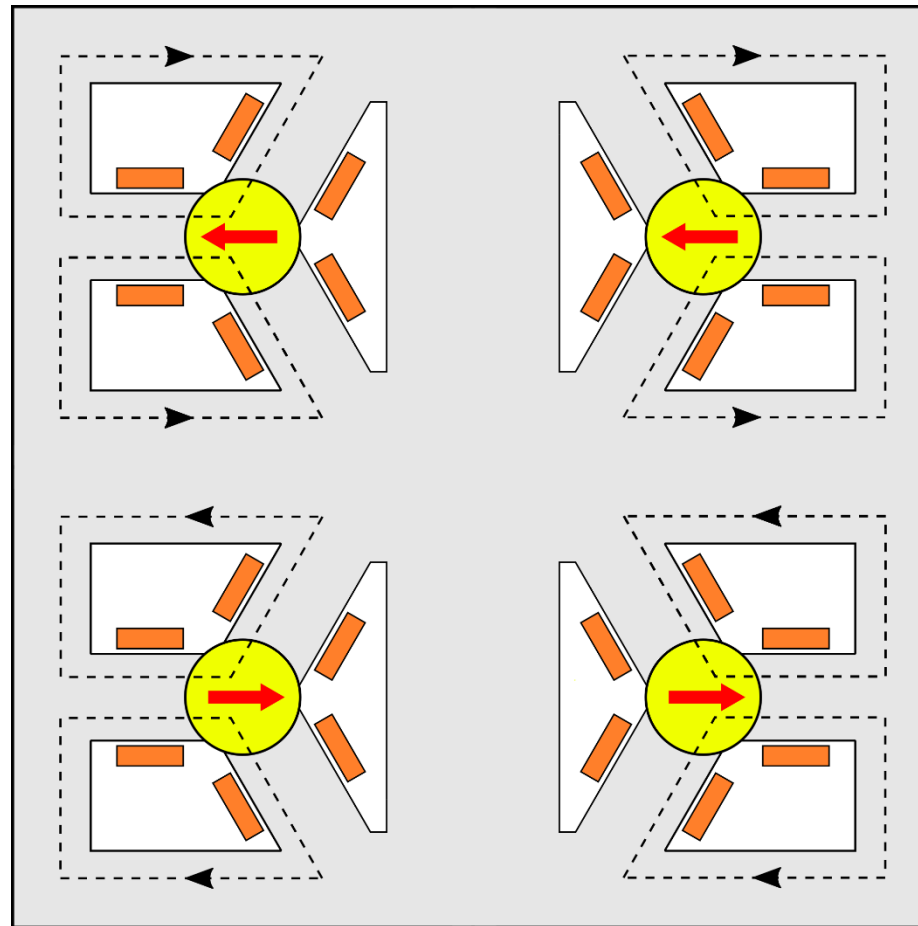

The Planetary Motor

- Areas of zero net flux

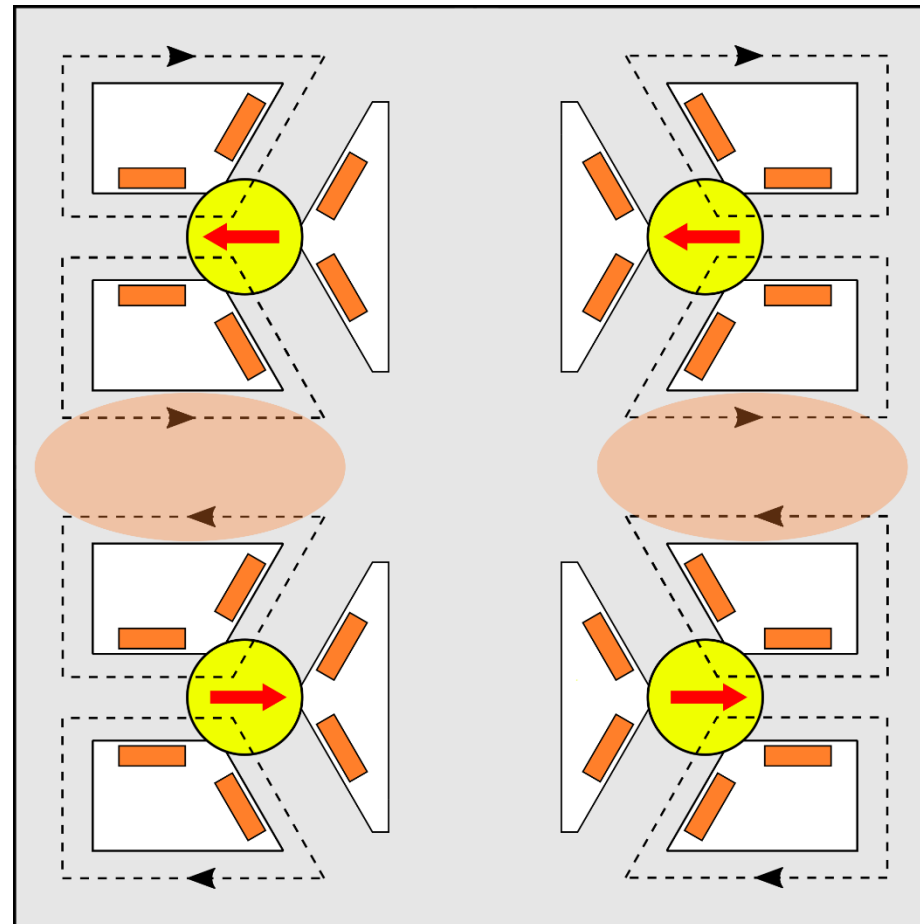

The Planetary Motor

- Areas of zero net flux

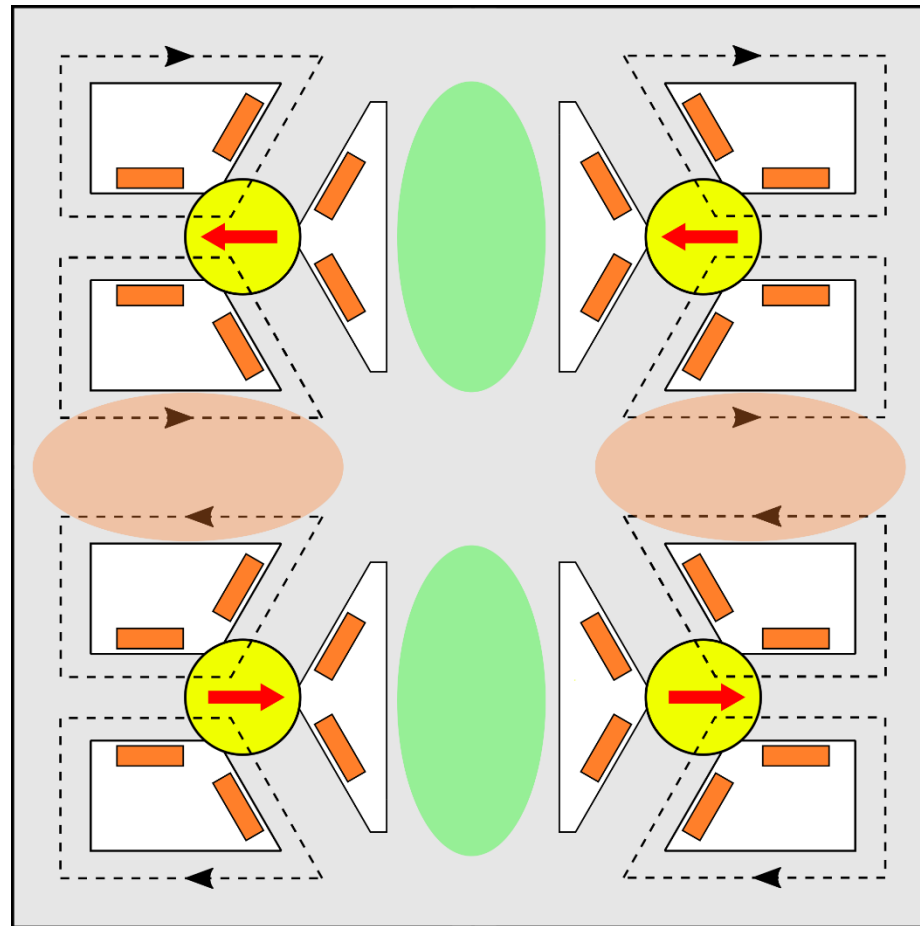

The Planetary Motor

- Rotors turn in opposite directions

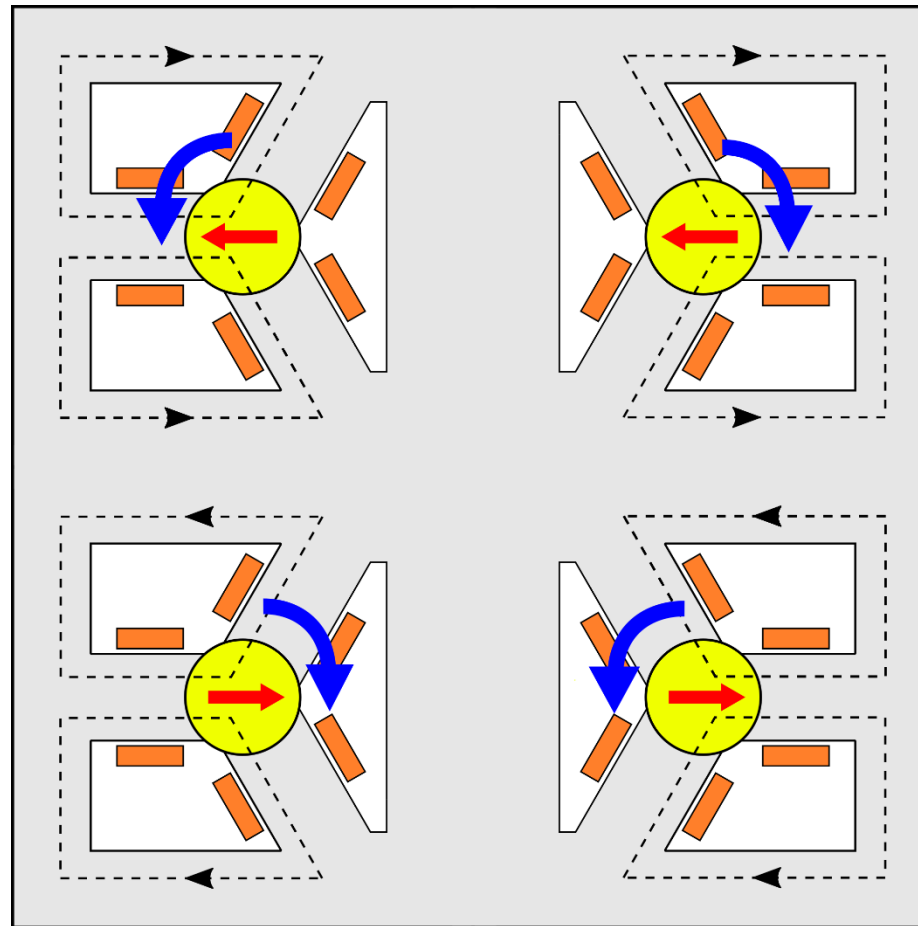

The Planetary Motor

- Rotors turn in opposite directions

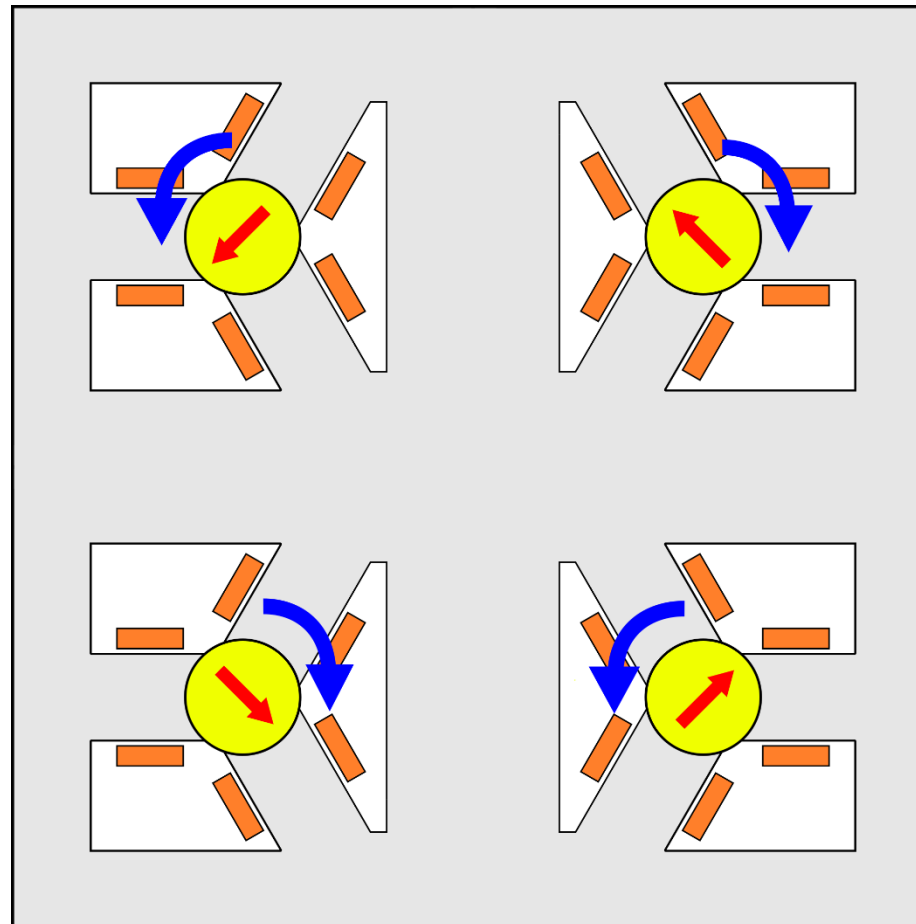

The Planetary Motor

- After 90deg: same areas with zero net flux

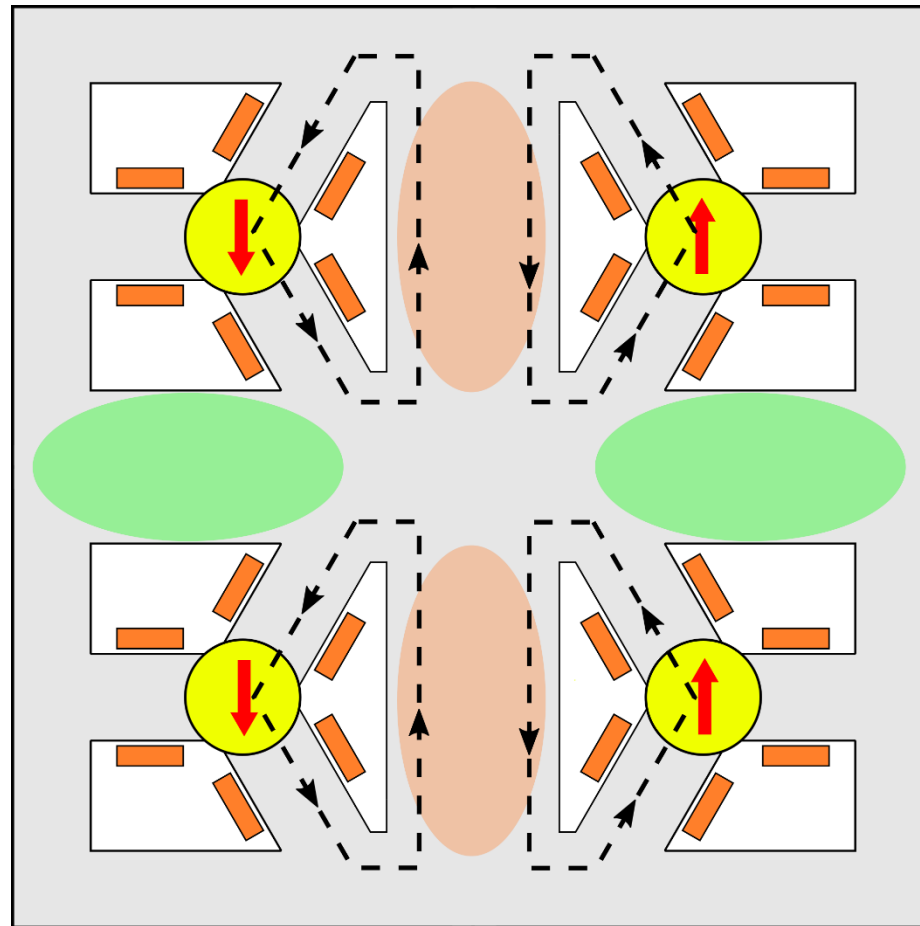

The Planetary Motor

- Omit magnetically inactive parts:

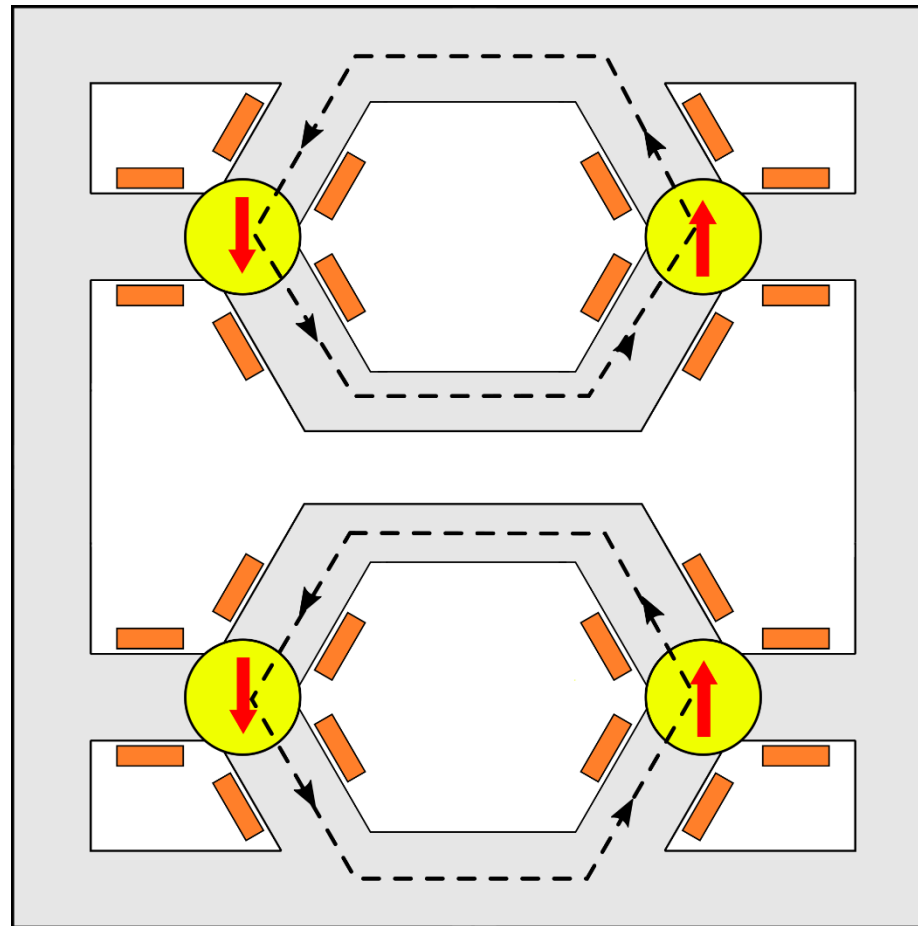

The Planetary Motor

- Corners are also magnetically inactive

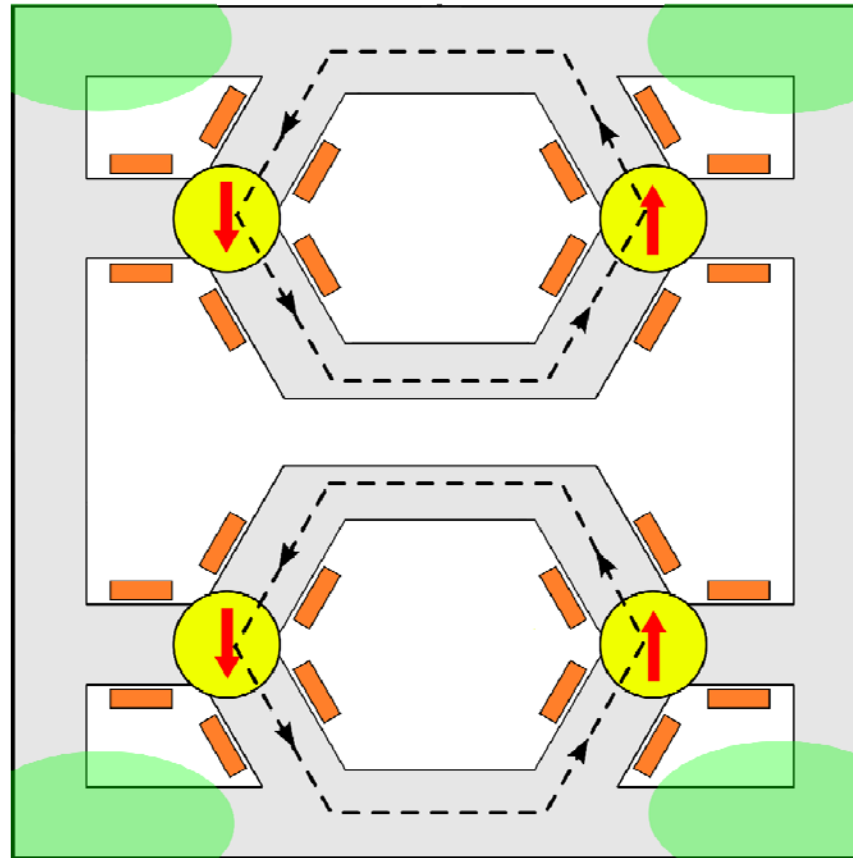

The Planetary Motor

- Corners are also magnetically inactive

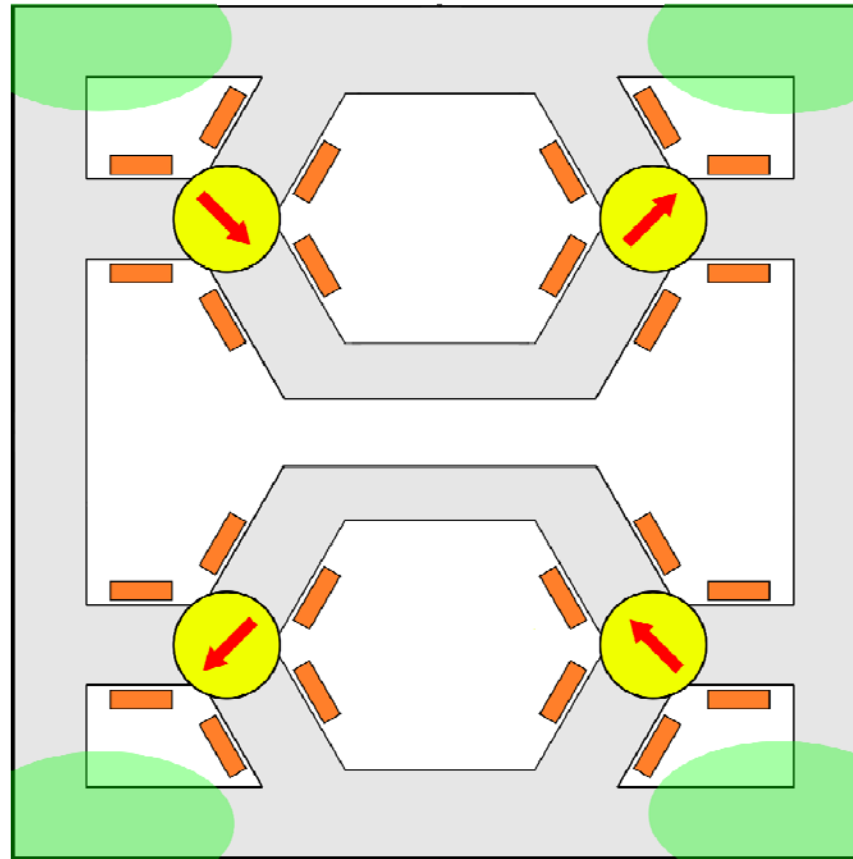

The Planetary Motor

- Corners are also magnetically inactive

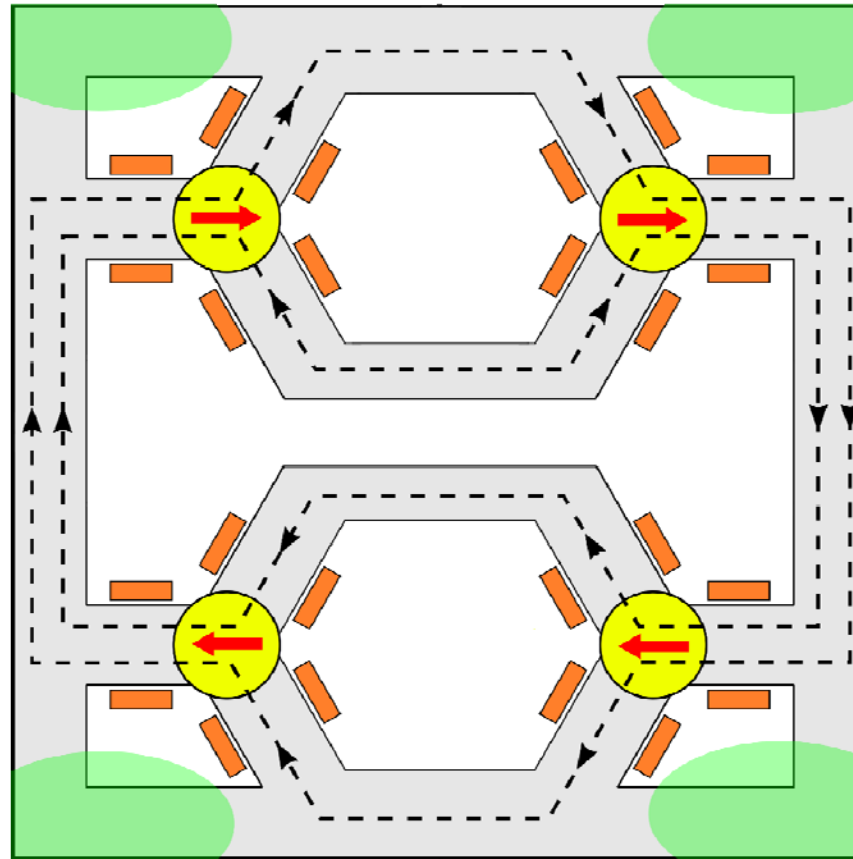

The Planetary Motor

- Corners are also magnetically inactive

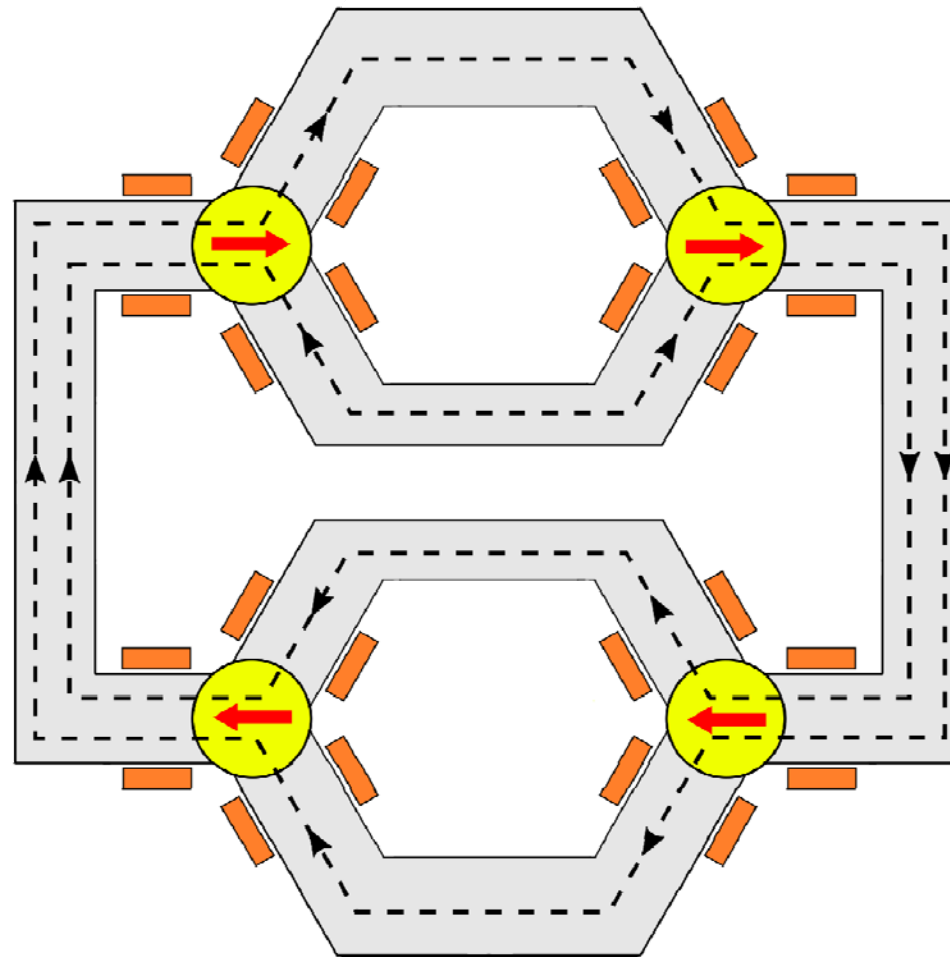

The Planetary Motor

- Omit magnetically inactive parts:

Reduced

- Active mass
- Motor volume
- Iron losses

Same power as 4
combined single motors

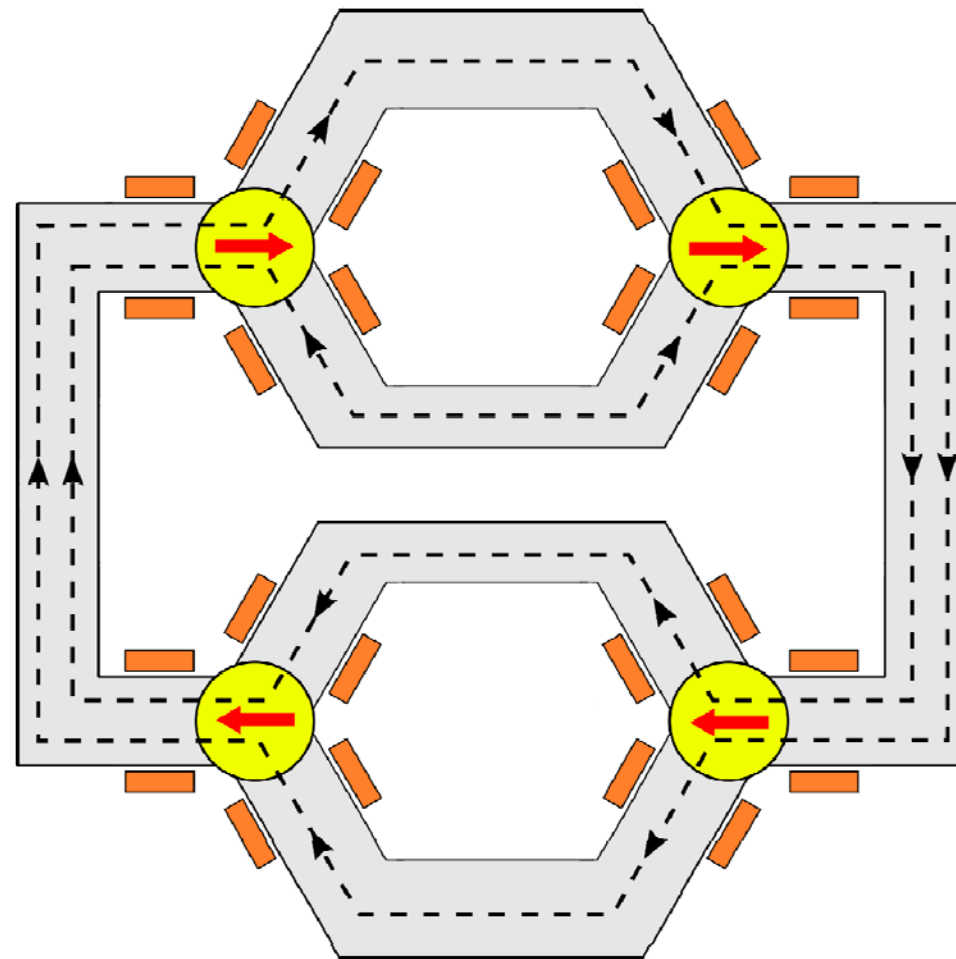

The Planetary Motor

- Combine coils

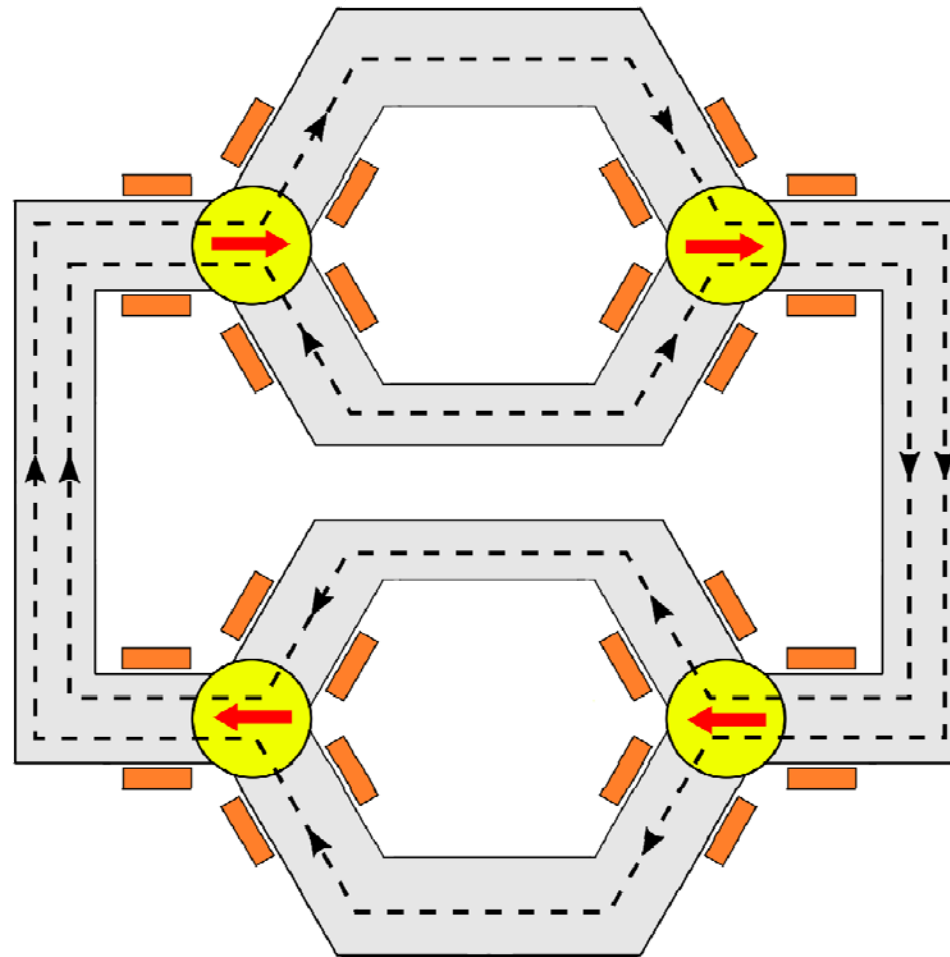

The Planetary Motor

- Combine coils

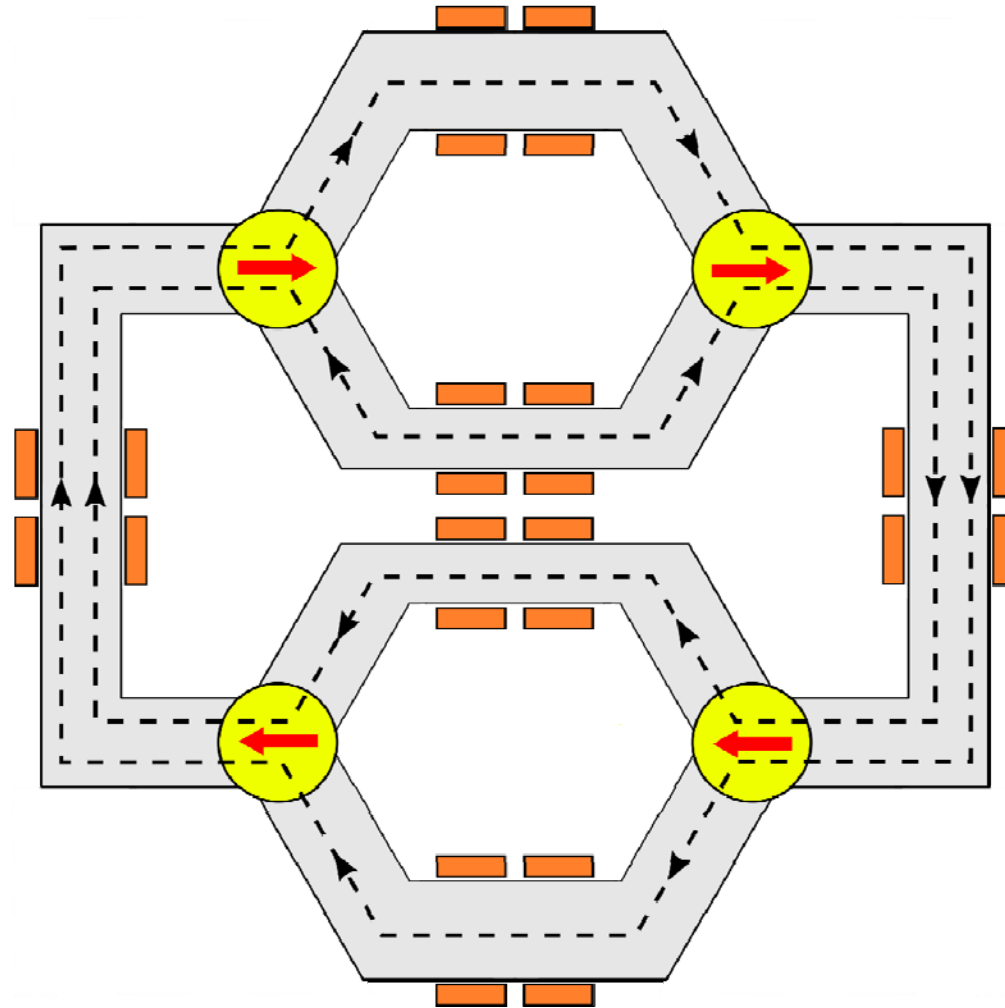

The Planetary Motor

- Combine coils: 12 coils \rightarrow 6 coils

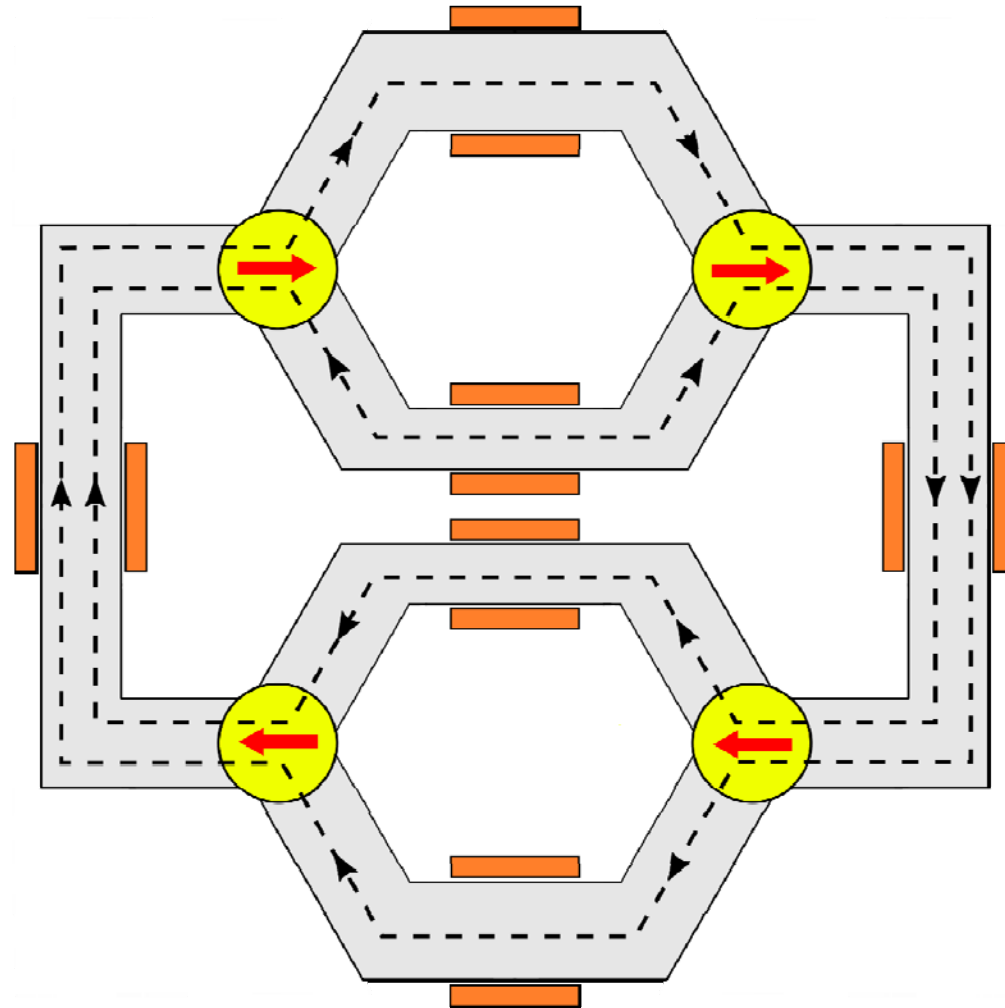

The Planetary Motor

- Integrated gear: sun gear

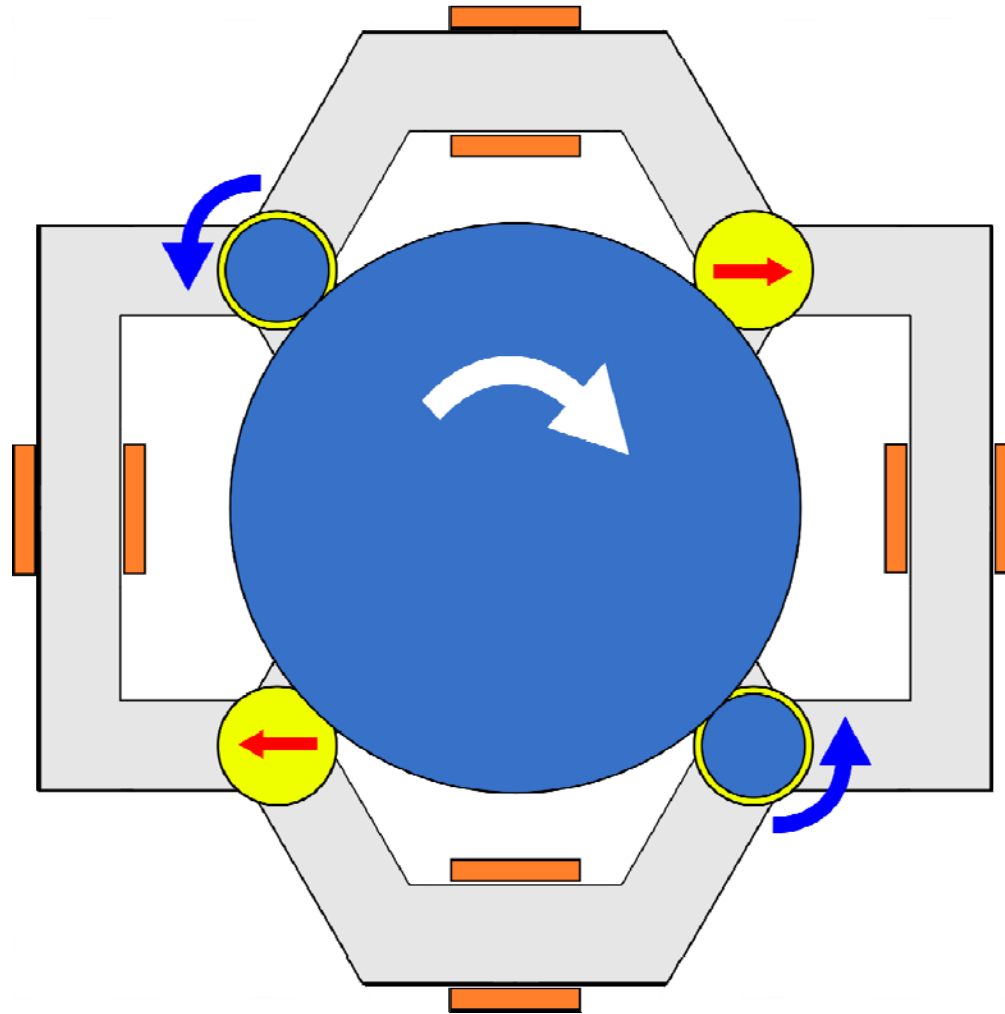

The Planetary Motor

- Integrated gear: ring gear

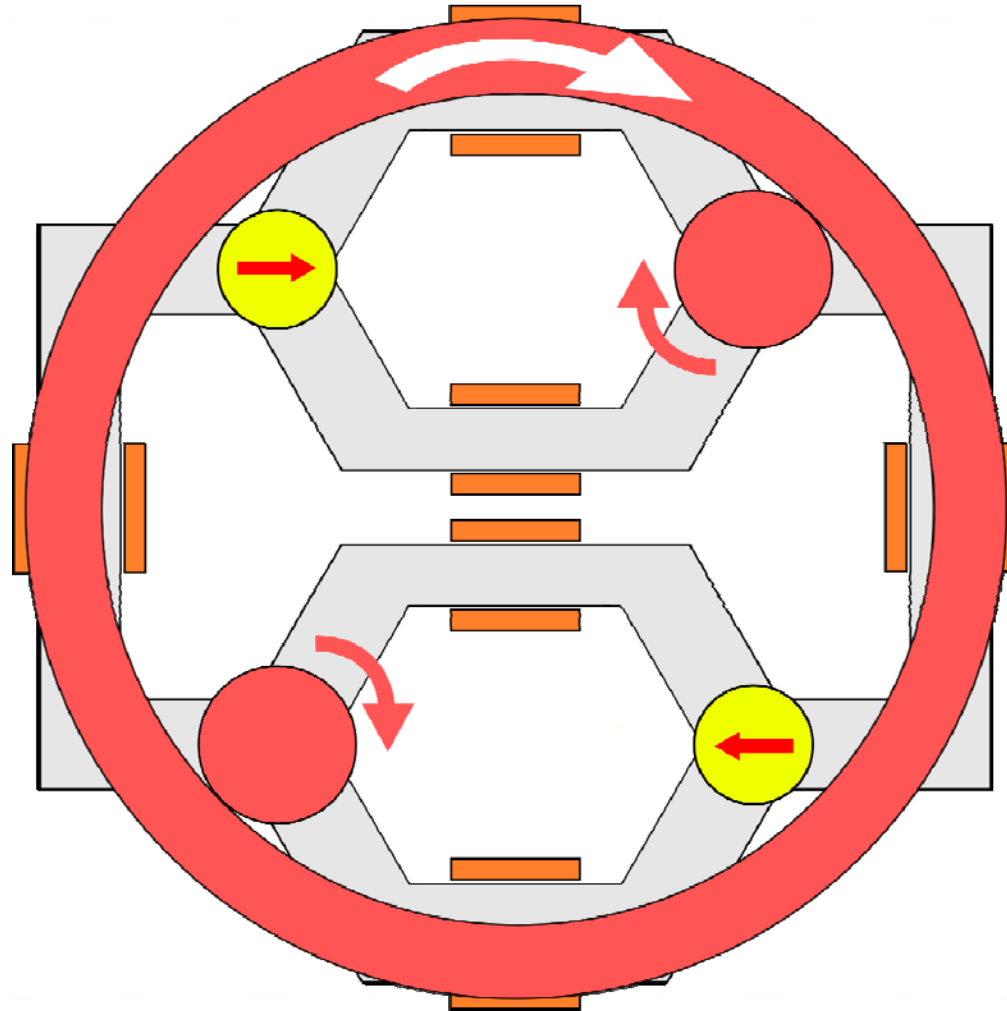

The Planetary Motor

- Integrated gear

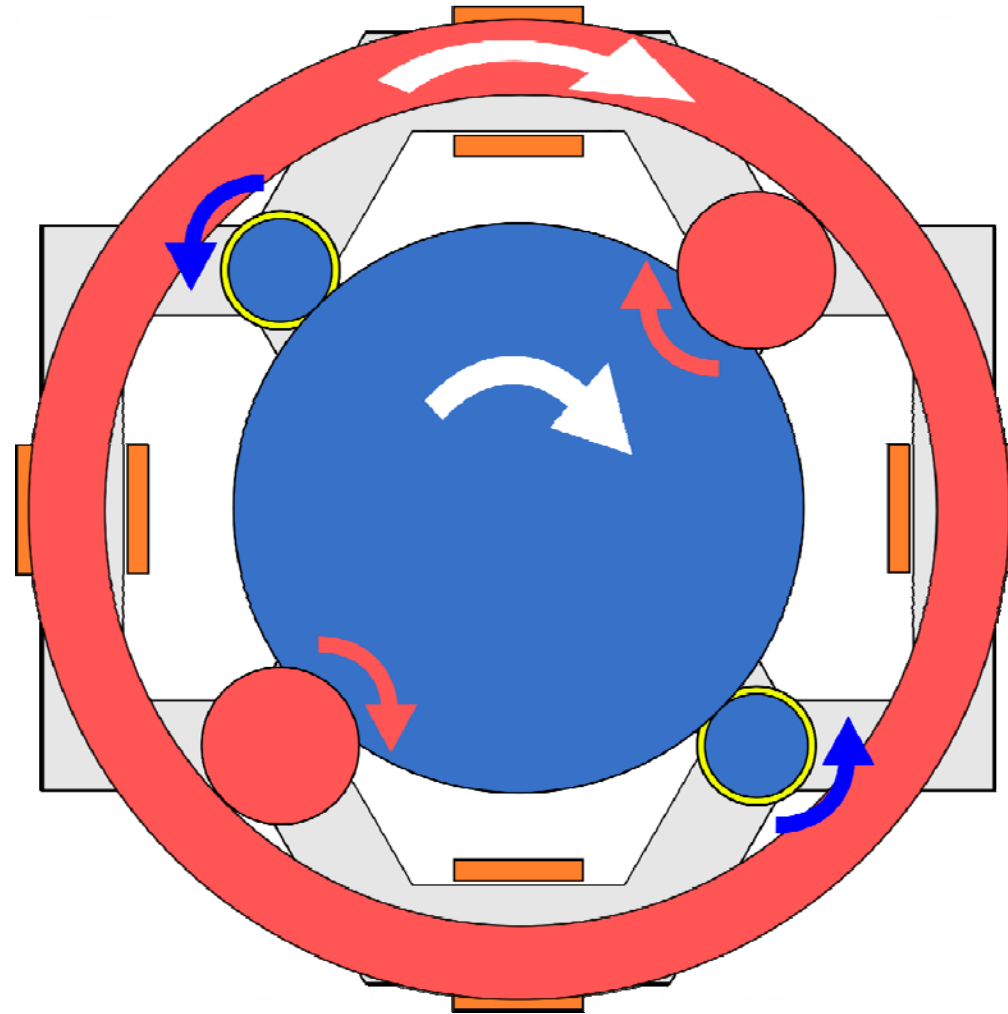

The Planetary Motor

- Integrated “planetary gear”
 - Sun gear and ring gear rotate at same speed → mechanical link for combined output power

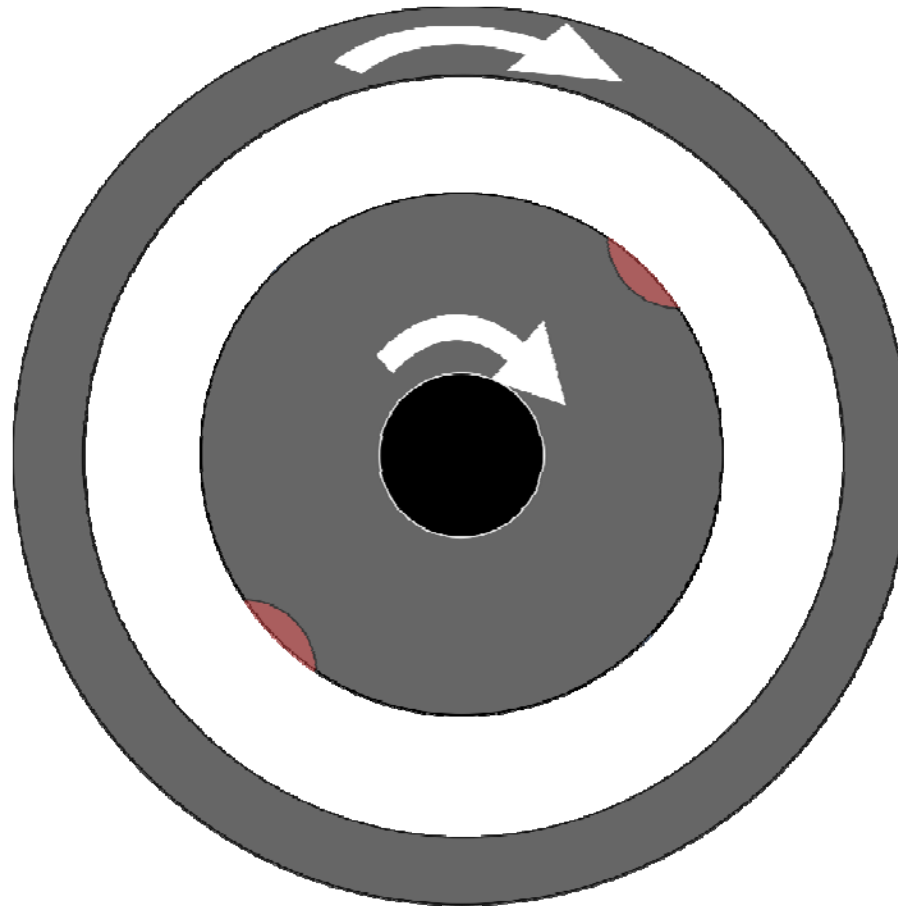

The Planetary Motor

- Integrated “planetary gear”
 - One point of contact for each gear (instead of two)
 - Gear ratios typ. 10:1

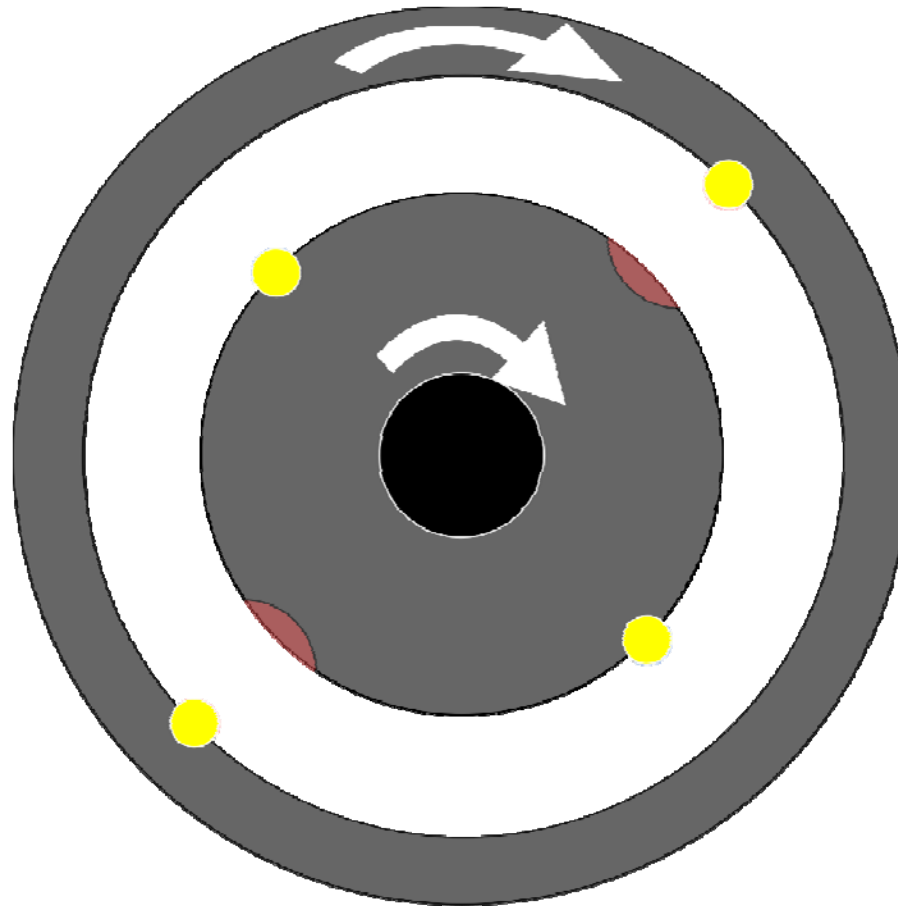

The Planetary Motor

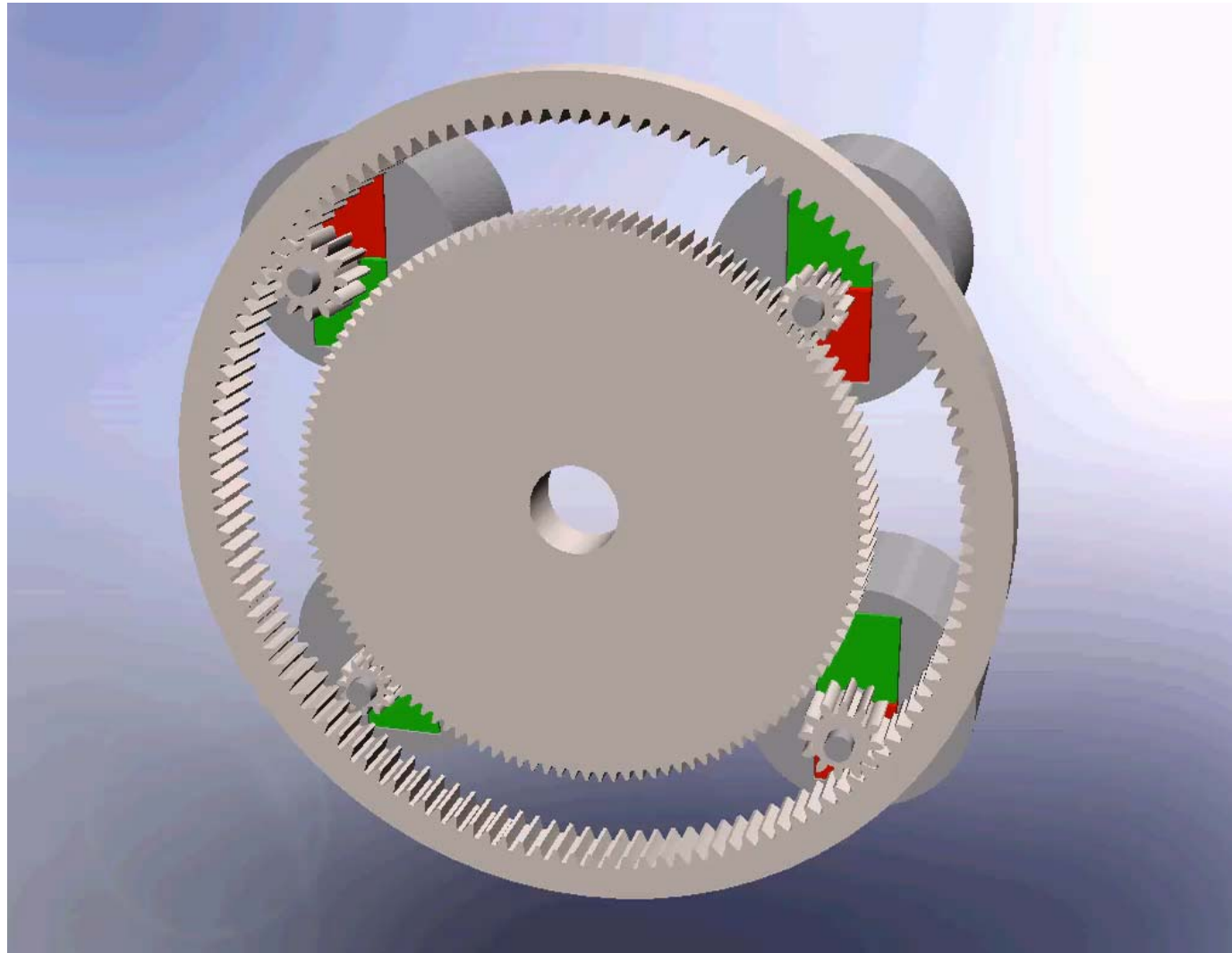

The Planetary Motor

Conventional motor + spur gear

R... gear ratio

v ... circumferential speed

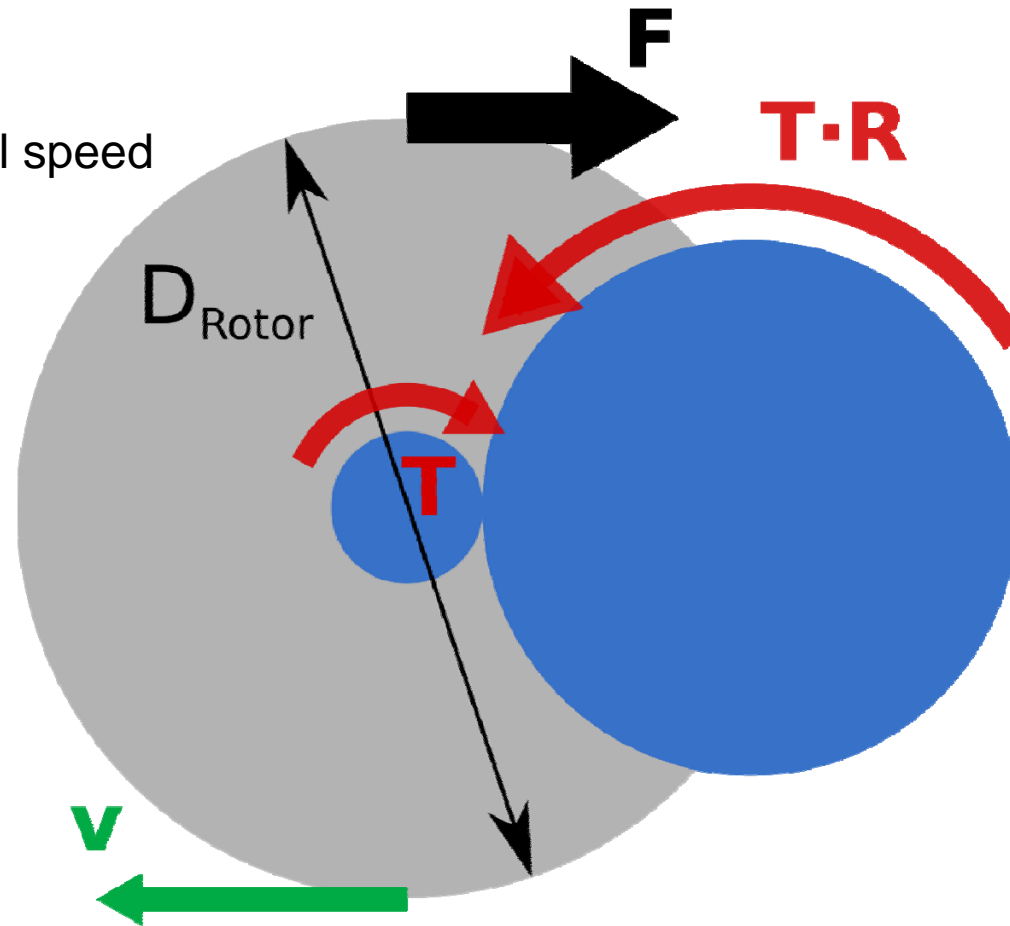

The Planetary Motor

Integrated Planetary gear

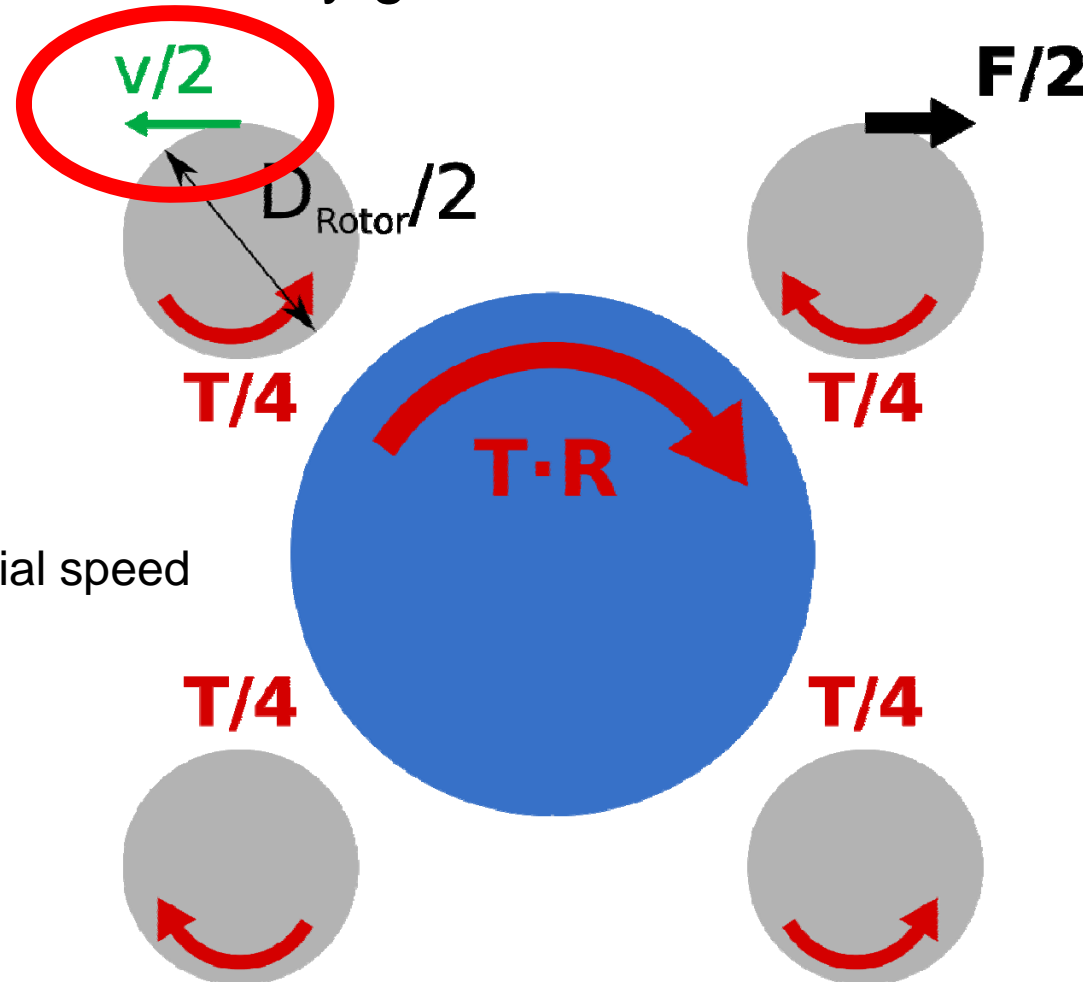

R... gear ratio

v ... circumferential speed

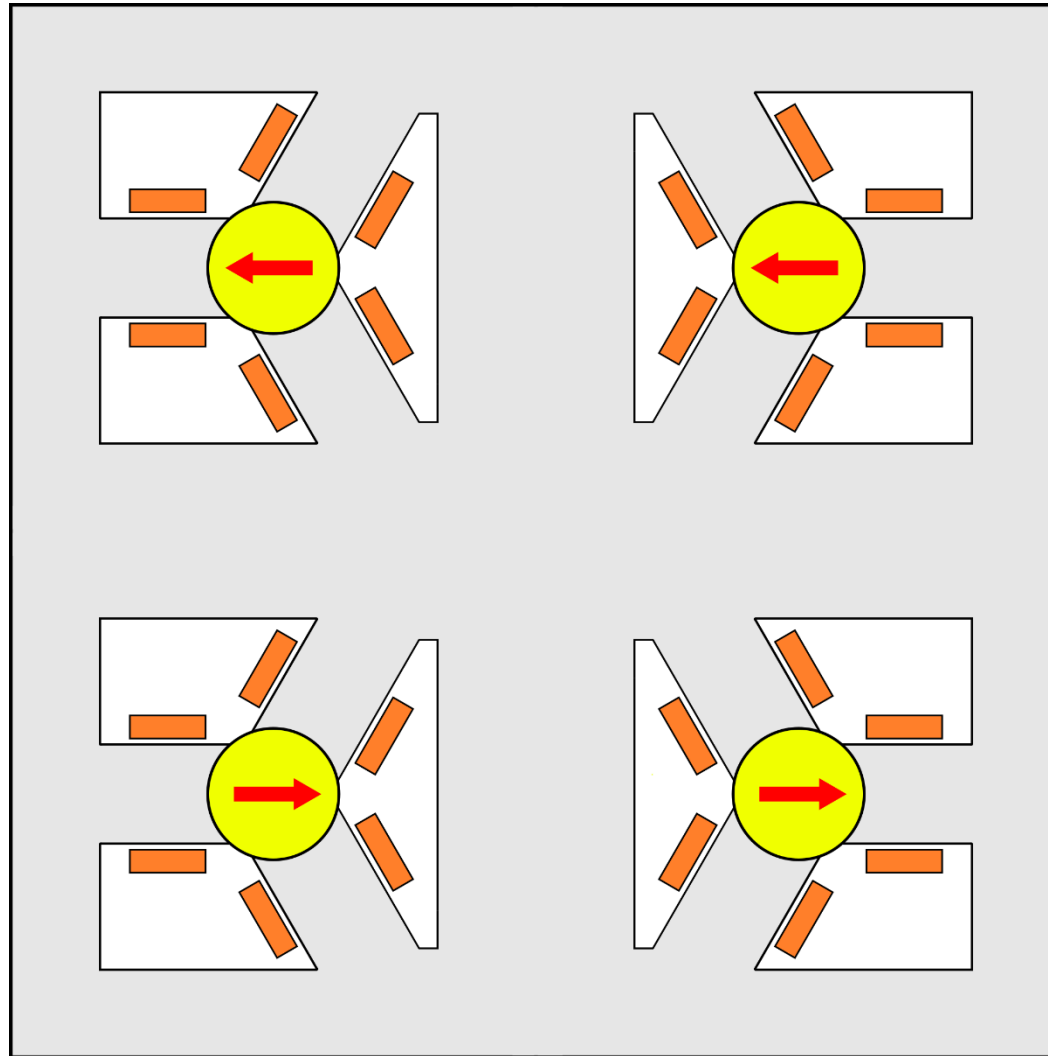

Original Circuit:

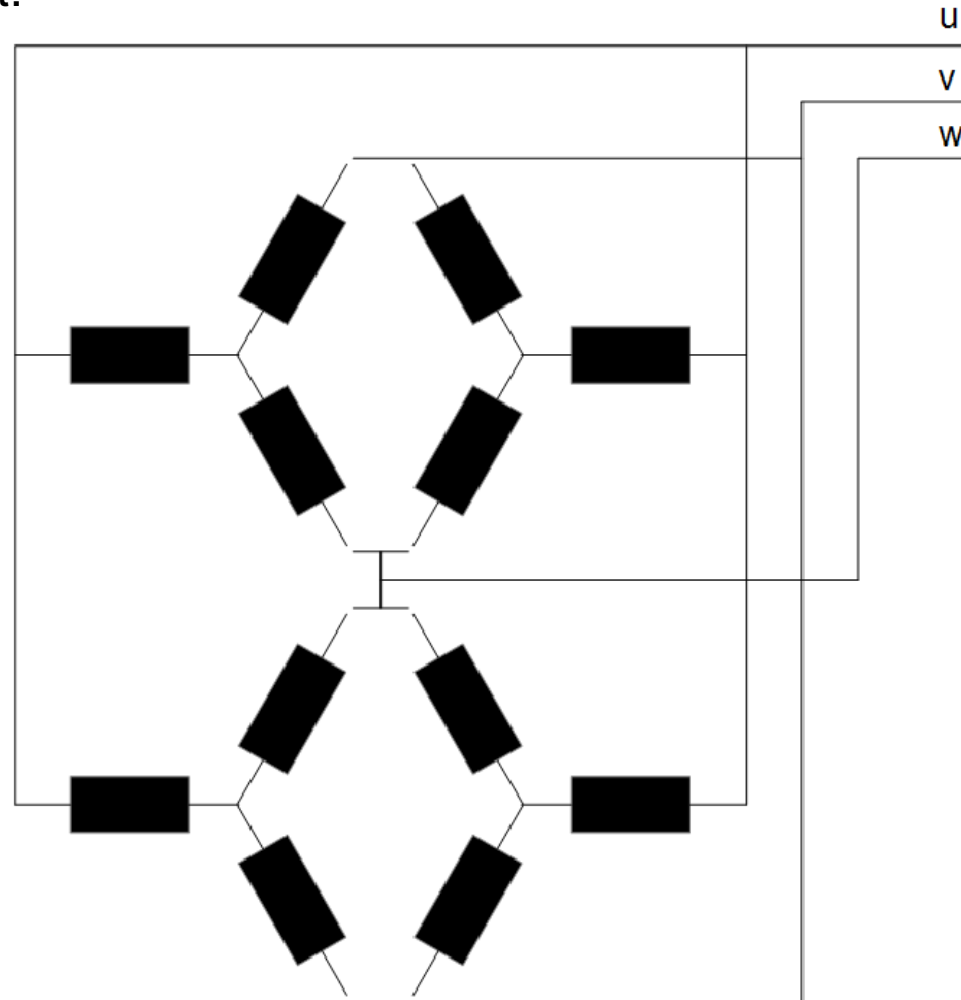

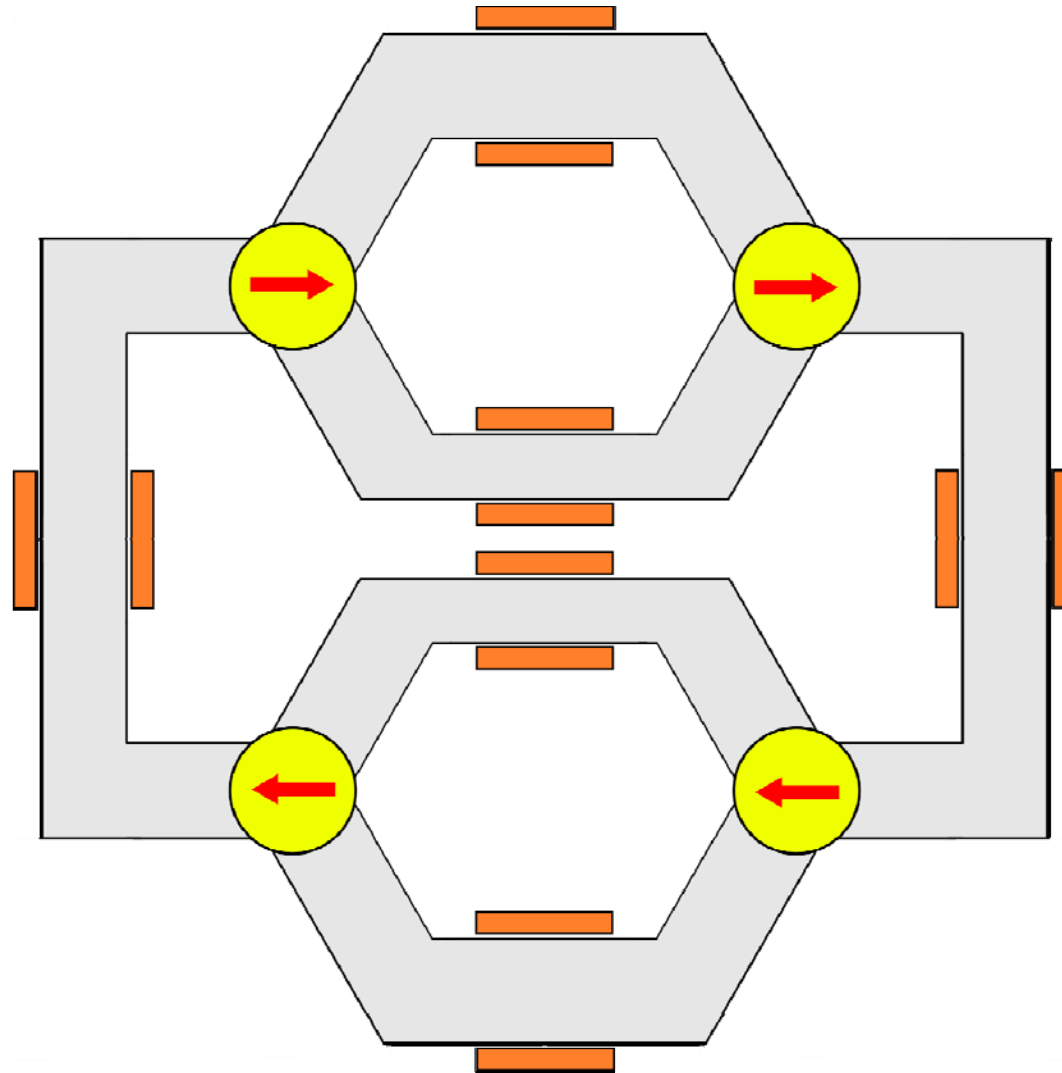

Reduced Circuit:

- 3-phase inverter
- Star or delta connection

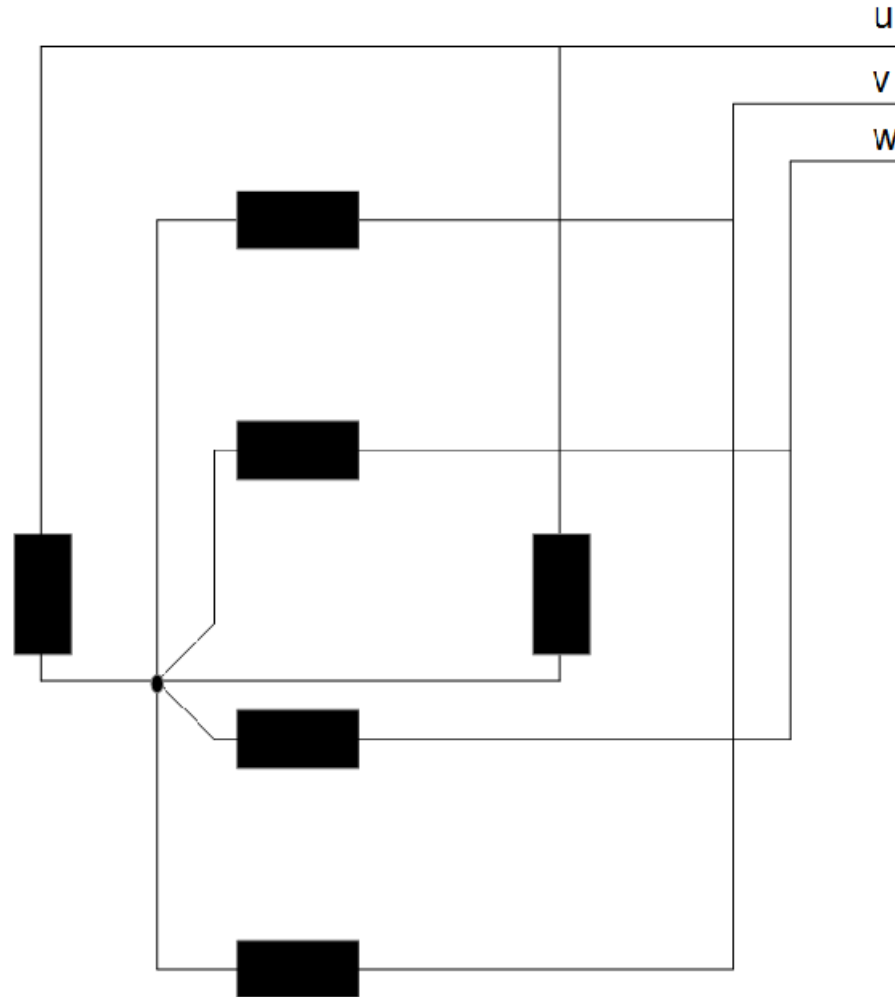

Functional Prototype

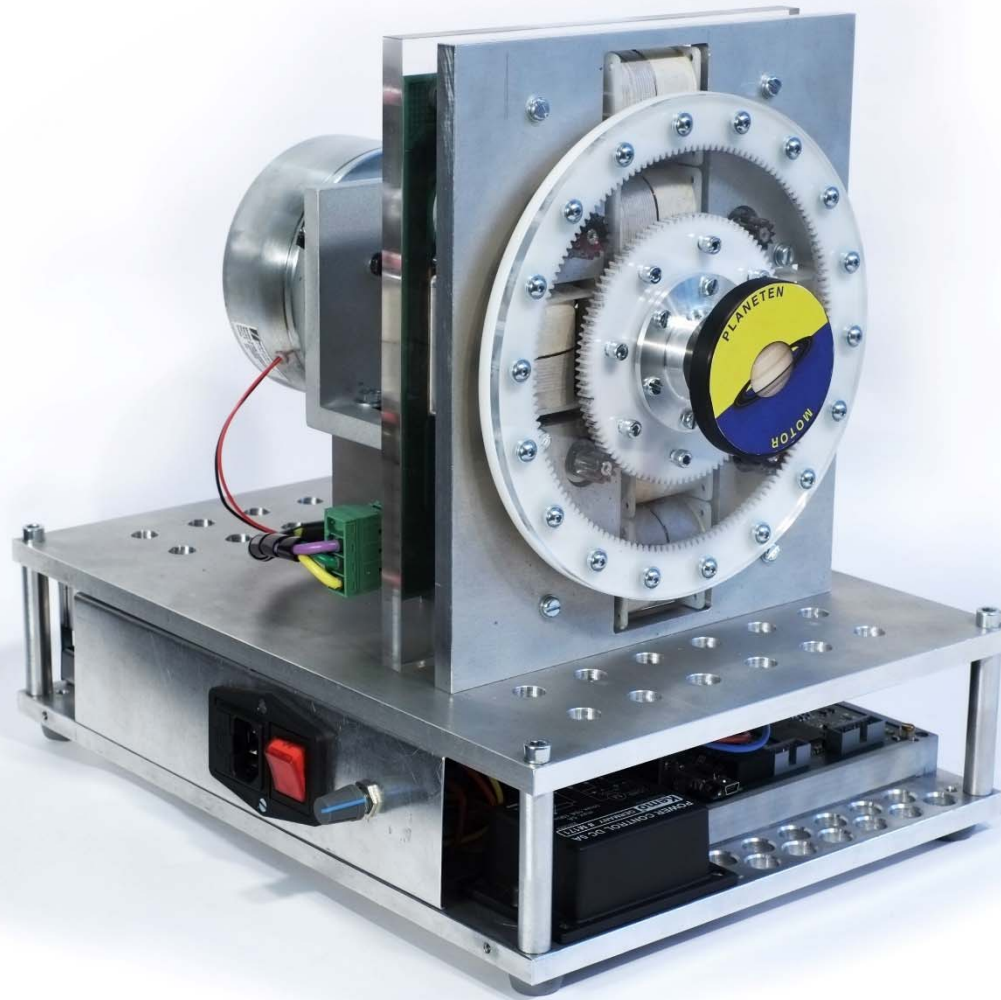

Functional Prototype

- 4 rotors and 3-phase stator winding
- 6 concentrated coils
- Gear ratio 10:1
- Sensorless control (INFORM / EMF)
- Connection of all coils on the rear side of the motor
 - Simple assembly

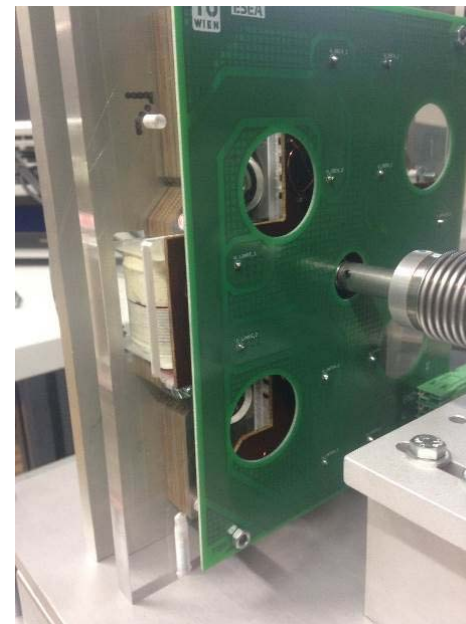

Functional Prototype

Terminal voltages at 200rpm on output shaft:

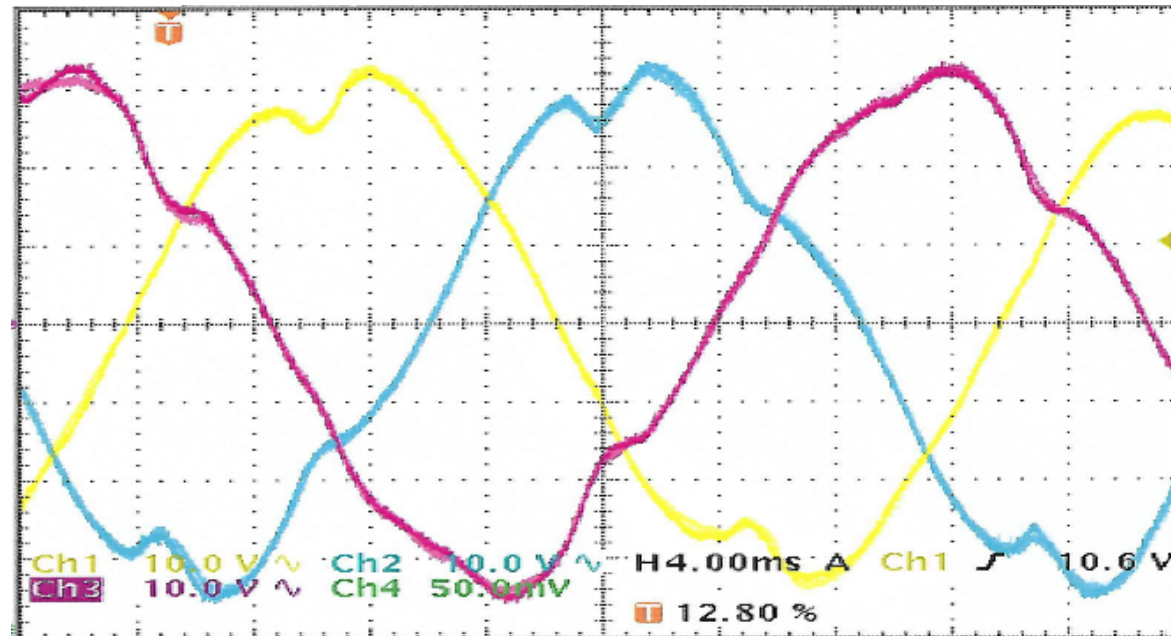

Control Strategy

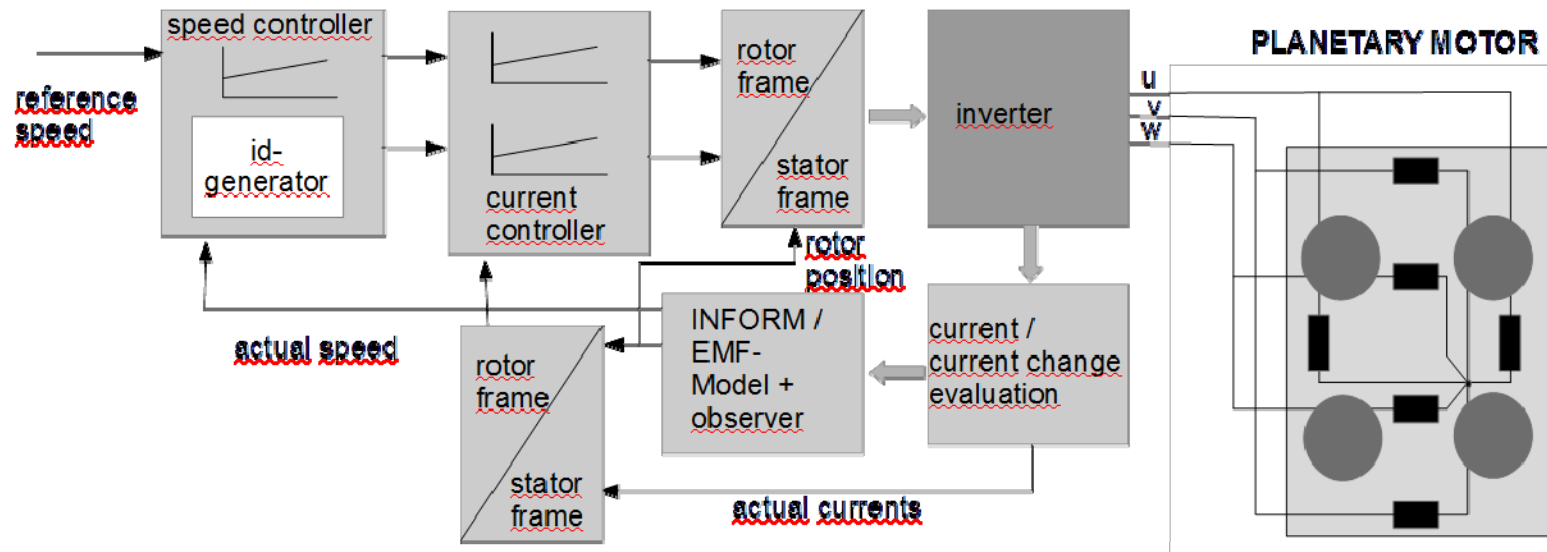

Control Strategy

- High-speed range ($> 10\%$ rated speed):
EMF-method
 - Based on induced voltage
 - State of the art
- Low-speed range and standstill:
INFORM® method
 - Based on inductance differences
 - Already used in series applications

$$\underline{l} = \frac{\underline{u}_s}{di_s/dt}$$

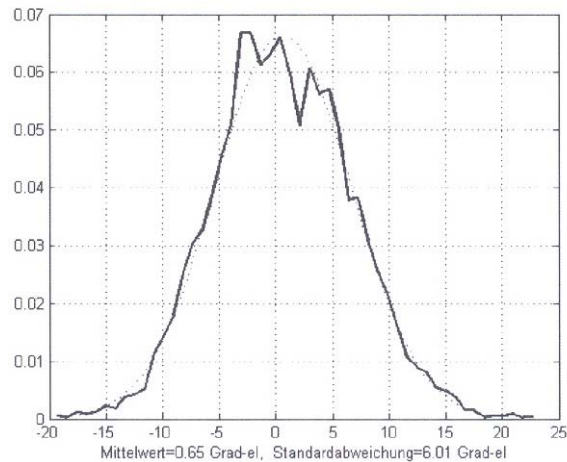
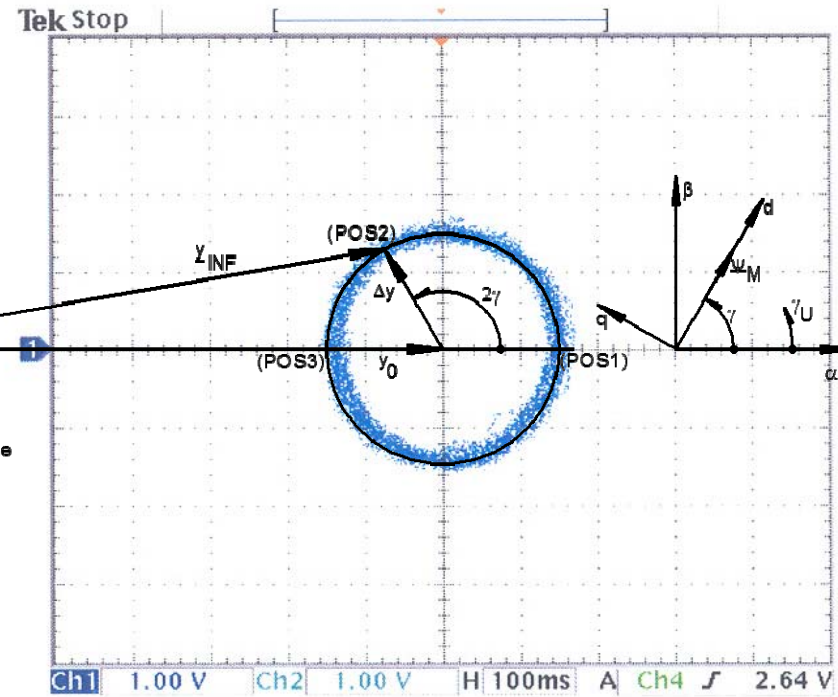
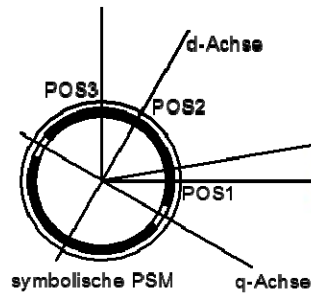

INFORM-error:

- mean 0.65deg
- Standard deviation 6.01deg (electrical)

Applications

- Electric vehicle axle drive
 - Integrated gear box
 - Hollow central motor shaft → differential drive

- Wheel-hub motor

- Low speed / high torque

- Wind power

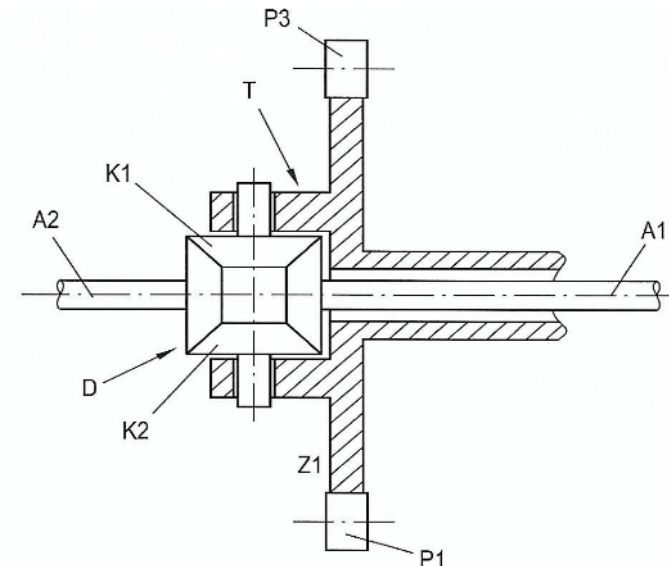

PLANETARY MOTOR with differential gear D (housing T, bevel wheels K1, K2), functionally combined with sun wheel Z1. Planets P1, P3 (shown without connected rotors of the electrical part). Half axes A1, A2, connected to driving wheels

- 4-pole rotors
- 12 coils

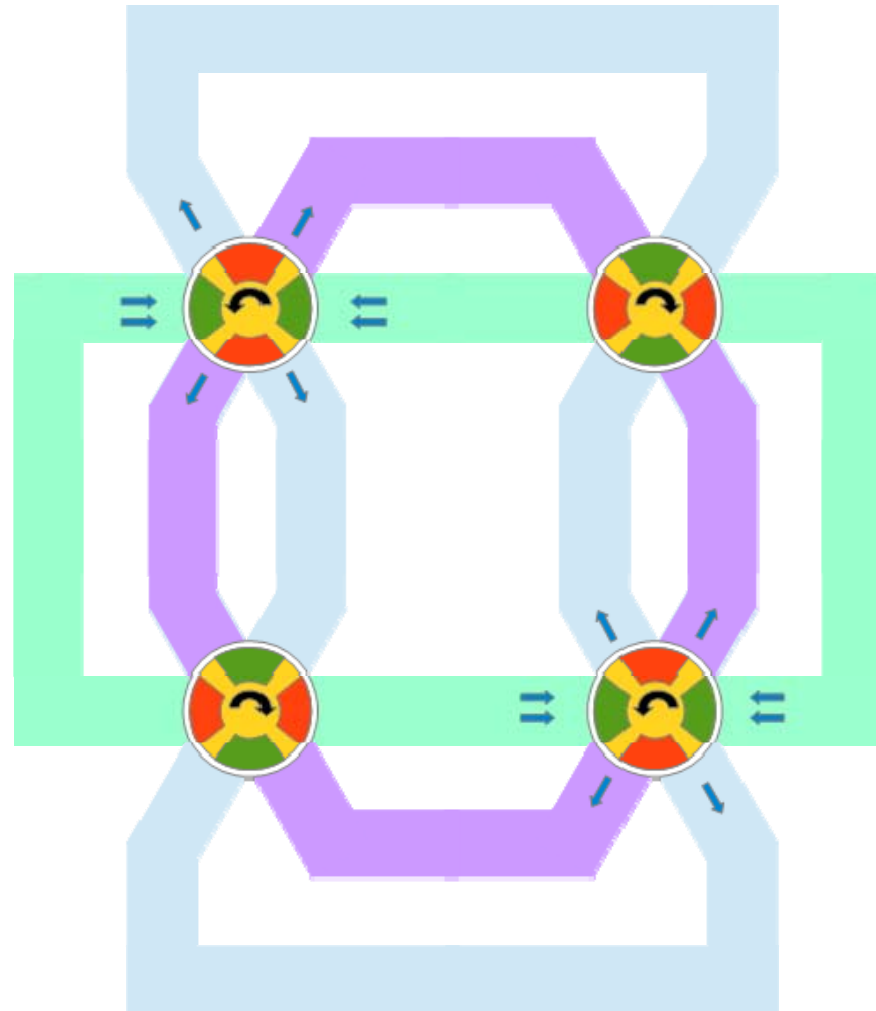

6 rotors (series connection of 3 elements)

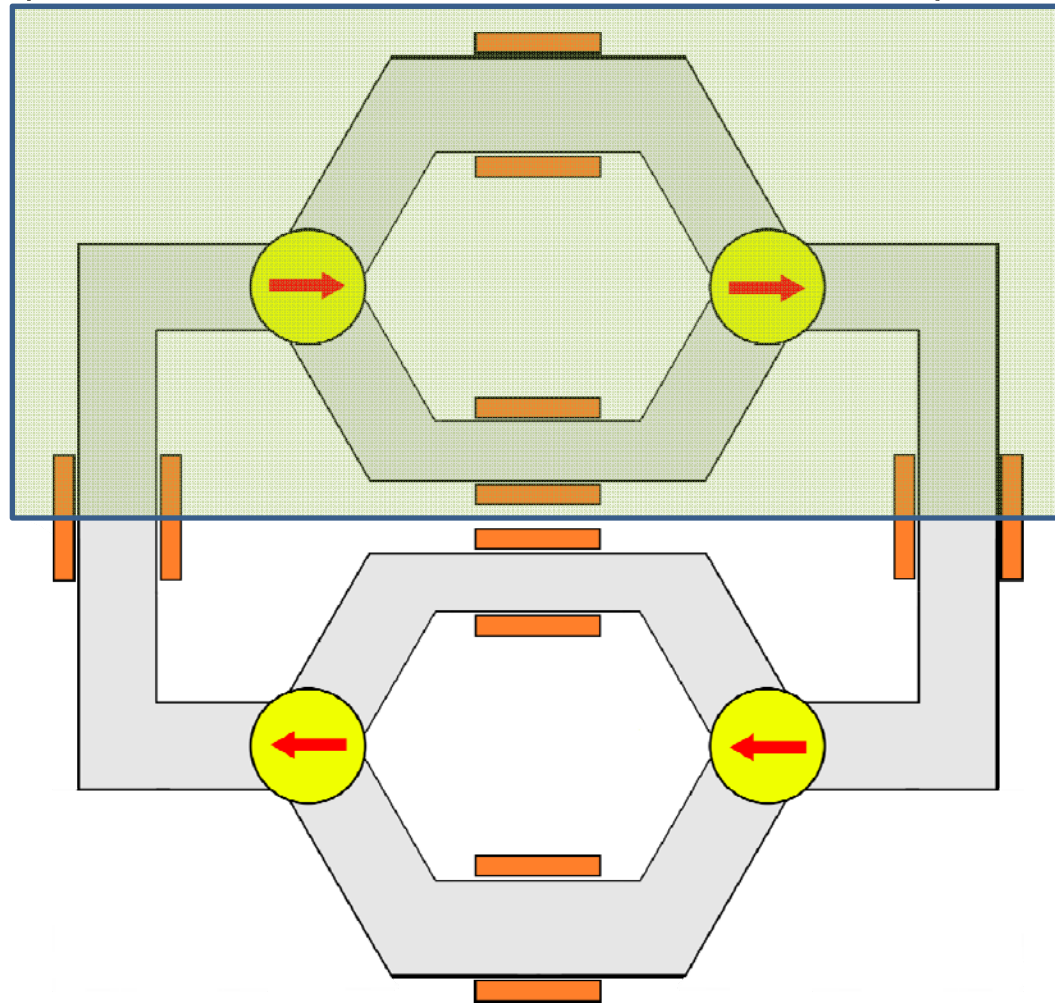

Conclusion

- 1 rotor → 4 rotors: half circumferential speed at same power
- Integrated transmission
 - Low speed / high torque applications
- Simple assembly
 - Concentrated coils
 - Integrated coil connections and power electronics on rear side possible
- Standard 3-phase inverters
 - Sensorless control



TECHNISCHE
UNIVERSITÄT
WIEN

ESEA

Thank you for your attention

TU Wien offers cooperation
Please contact us!

Manfred.schroedl@tuwien.ac.at